

# **MOBIL LYDONIA CANYON BLOCK 273 No. 1 WELL**

## **Geological and Operational Summary**

Edited by:

Gary M. Edson  
Donald L. Olson  
Andrew J. Petty

U. S. Department of the Interior  
Minerals Management Service  
Gulf of Mexico OCS Region  
Office of Resource Evaluation

New Orleans  
May 2000



# CONTENTS

Abbreviations, vi
Introduction, 1
Operational Summary, 2
Well Velocity Profile, 8
Lithologic Interpretation., 12
Biostratigraphy, 15
Formation Evaluation, 16
Geothermal Gradient, 21
Kerogen Analysis, 23
Burial History, 31
Company-submitted Data, 33
Selected References, 34

## ILLUSTRATIONS

- Figure
1. Map of the North Atlantic offshore area showing well locations, 3
  2. Location plat for the Mobil Block 273 No. 1 well on the OCS Lydonia Canyon NK 19-12 protraction diagram, 4
  3. Daily drilling progress for the Mobil Lydonia Canyon Block 273 No. 1 well, 5
  4. Casing diagram for the Mobil Lydonia Canyon Block 273 No. 1 well, 7
  5. Well velocity profile for the Mobil Lydonia Canyon Block 273 No. 1 well, plotted against depth, 9
  6. Well velocity profile for the Mobil Lydonia Canyon Block 273 No. 1 well, plotted against two-way travel time, 10
  7. Columnar chart of the lithology, biostratigraphy, and paleobathymetry of the Mobil Lydonia Canyon Block 273 No. 1 well, 13
  8. Well temperatures and geothermal gradient for the Mobil Lydonia Canyon Block 273 No. 1 well, 22
  9. Relationships among coal rank, percent  $R_o$ , TAI, spore color, and thermal zones of hydrocarbon generation, 24
  10. Graph of kerogen types, total organic carbon (TOC), and organic thermal maturity for the Mobil Lydonia Canyon Block 273 No. 1 well, 25
  11. Burial diagram for the Mobil Lydonia Canyon Block 273 No. 1 well, 32

## TABLES

Table	1. Well statistics, 6
	2. Well velocity data, 8
	3. Well velocity intervals, 11
	4. Biostratigraphy and depositional environments, 15
	5. Well logs, 16
	6. Well log interpretation summary, 17
	7. Sidewall core summary, 18
	8. Dipmeter data summary, 19
	9. Hydrocarbon shows, 20
	10. Relative kerogen abundances, 26
	11. Total organic carbon analysis, 27

## ABBREVIATIONS

API	-- American Petroleum Institute
bbbl	-- barrels
BOP	-- Blow out preventer
CNL	-- Compensated neutron log
CPI	-- Carbon Preference Index
COST	-- Continental Offshore Stratigraphic Test
DST	-- drill stem test
EQMW	-- equivalent mud weight
FDC	-- compensated formation density log
FEL	-- from east line
FNL	-- from north line
FSL	-- from south line
FWL	-- from west line
k	-- permeability
KB	-- kelly bushing
LS	-- limestone
m	-- meter (s)
md	-- millidarcy
MYBP	-- million years before present
OCS	-- Outer Continental Shelf
ppf	-- pounds per foot
ppg	-- pounds per gallon
ppm	-- parts per million
psi	-- pounds per square inch
R <sub>o</sub>	-- vitrinite reflectance
SS	-- sandstone
Sw	-- water saturation
TAI	-- thermal alteration index
TD	-- total depth
TIOG	-- threshold of intense oil generation
TOC	-- total organic carbon
UTM	-- Universal Transverse Mercator
φ	-- porosity

## INTRODUCTION

The Mobil Lydonia Canyon (LC) Block 273 No. 1 well was the last to be spudded and seventh to be completed of the eight industry wildcat wells drilled on Georges Bank. Spudded on June 30, 1982, this well is near the center of the group of wells drilled on Georges Bank. It is about 11 miles south of the Continental Offshore Stratigraphic Test (COST) G-2 well. The Mobil LC Block 273 No. 1 well was drilled by a semi-submersible rig in 301 feet of water on the continental shelf about 135 miles east-southeast of Nantucket Island and 15 miles from the shelf edge.

Mobil Exploration and Producing Services, Inc. (Mobil), was the designated operator for the well, and the company's primary drilling target was a group of high-amplitude seismic reflectors ("bright spots") from 2.2 to 2.6 seconds, two-way travel time, showing four-way closure. The company interpreted the target to be Upper and Middle Jurassic oolitic and bioclastic limestones at depths of 10,000 to 14,000 feet. The underlying structure was interpreted to be a salt swell. Within the target zone, Mobil encountered tight micritic limestones with minor oolites, pellets, and fossil fragments, as well as sandstone, siltstone, and shale interbeds. There were no significant hydrocarbon shows. No petrophysical tests were done on sidewall cores, no conventional cores were cut, and no well tests were attempted. The Mobil LC Block 273 No. 1 well was

plugged and abandoned as a dry hole on September 13, 1982.

This report relies on geologic and geophysical data provided to the Minerals Management Service (MMS) by Mobil, according to Outer Continental Shelf (OCS) regulations and lease stipulations. The data were released to the public after the Lydonia Canyon Block 273 lease No. OCS-A-0196 expired on January 31, 1985. Interpretations of the data contained in this report are those of MMS and may differ from those of Mobil. Well depths are measured from kelly bushing (measured depths) unless otherwise stated.

The material contained in this report is from unpublished, undated MMS internal interpretations. No attempt has been made to provide more recent geologic, geochemical, or geophysical interpretations or data, published, or unpublished.

This report is initially released on the Minerals Management Service Internet site <http://www.gomr.mms.gov>, and, together with the other Georges Bank well reports, on a single compact disk (CD). At a later date, additional technical data, including well "electric" logs will be added to the CD.

## OPERATIONAL SUMMARY

The Mobil Lydonia Canyon (LC) Block 273 No. 1 well (figures 1 and 2) was drilled by the Rowan Companies, Inc., *Rowan Midland* semisubmersible drilling rig to a total depth of 15,580 feet. The well was spudded on June 30, 1982, in 301 feet of water. Daily drilling progress for the well is shown in figure 3 and well statistics are presented in table 1. The primary geologic objectives were between 10,000 and 14,000 feet and were interpreted to be Middle and Upper Jurassic oolitic and bioclastic limestones on a south-southeast-plunging nose having structural closure at the well location. Structural relief increases with depth, and the nose may overlie a salt swell. Any hydrocarbons encountered were expected to be gas and perhaps condensate.

The surface hole was drilled to 572 feet, and a 30-inch 5-L (456 and 309 ppg) casing was set at 546 feet and cemented with 800 sacks of class H cement with 2 percent CaCl weighing 16.4 ppg (figure 4).

The riser was connected and a 26-inch hole was drilled to 1,503 feet. A 20-inch class H-40 (94 ppg) casing was set at 1,389 feet and cemented with 750 sacks of class H cement with 4 percent prehydrated gel, weighing 12.4 ppg, followed by 320 sacks of class H cement with 1 percent CaCl weighing 16.4 ppg. The 20-inch casing shoe was tested to 500 psi with 8.8-ppg mud. A formation integrity test was successful to 270 psi (12.5 EQMW). The blowout preventer was then connected and tested.

The section to 4,850 feet was drilled in 70 hours using three bits at an average rate of

penetration of 49 feet per hour, ranging from 30 to 80 feet per hour. Background gas averaging zero to 2 units, with a maximum of 18 units, occurred in unconsolidated sand at 1,400 feet. Caustic sea-water-gel mud with various additives was used with weights varying from 8.9 to 9.2 ppg. Type S-95 13 3/8-inch (72 ppg) casing was set at 4,818 feet using 862 sacks of class H cement with 3 percent bentonite, weighing 12.9 ppg, followed by 1,438 sacks neat of class H cement with a weight of 16.4 ppg. The shoe was tested to 1,250 psi, drilled out, and a formation integrity test of 1,250 psi with 9.1 ppg mud (14 ppg, EQMW) was taken.

The section to 14,095 feet was drilled in 748 hours using 13 bits at an average rate of penetration of 12 feet per hour, ranging from 6.5 to 100 feet per hour. Caustic gel mud, with additives, was used with weights varying from 9.2 to 9.5 ppg. Background gas averaged zero to three units with two shows in limestone, 38 units at 9,930 feet and 35 units at 13,930 feet. Drilling continued to a total depth of 15,580 feet without setting additional casing. Mud weight was increased to 10.8 ppg at 14,095 feet. Total depth was reached in 978.1 hours using 21 bits at an average rate of penetration of 31 feet per hour, ranging from 5 to 800 feet per hour. Background gas averaged three to four units with no significant gas shows. Schlumberger performed final well tests and logging on September 6.

Abandonment procedures began on September 7 and are shown in figure 4. Open-hole plugs were placed with their tops at 9,757 and 4,733 feet, using 275

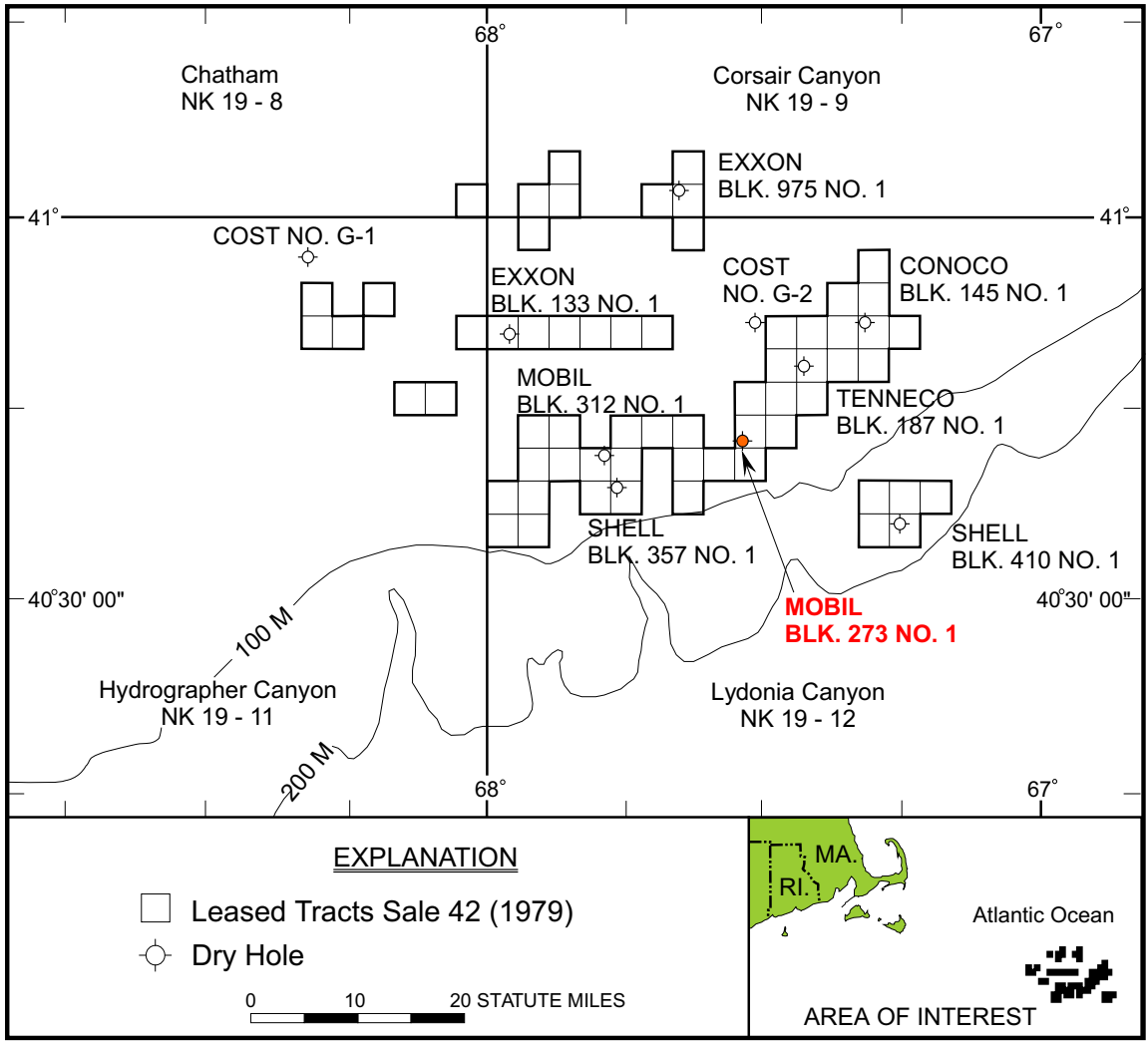

Figure 1. Map of the North Atlantic offshore area showing well locations. The Mobil Lydonia Canyon Block 273 No. 1 well is highlighted in red. Bathymetry is in meters.

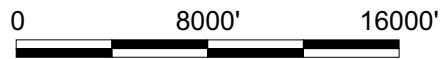
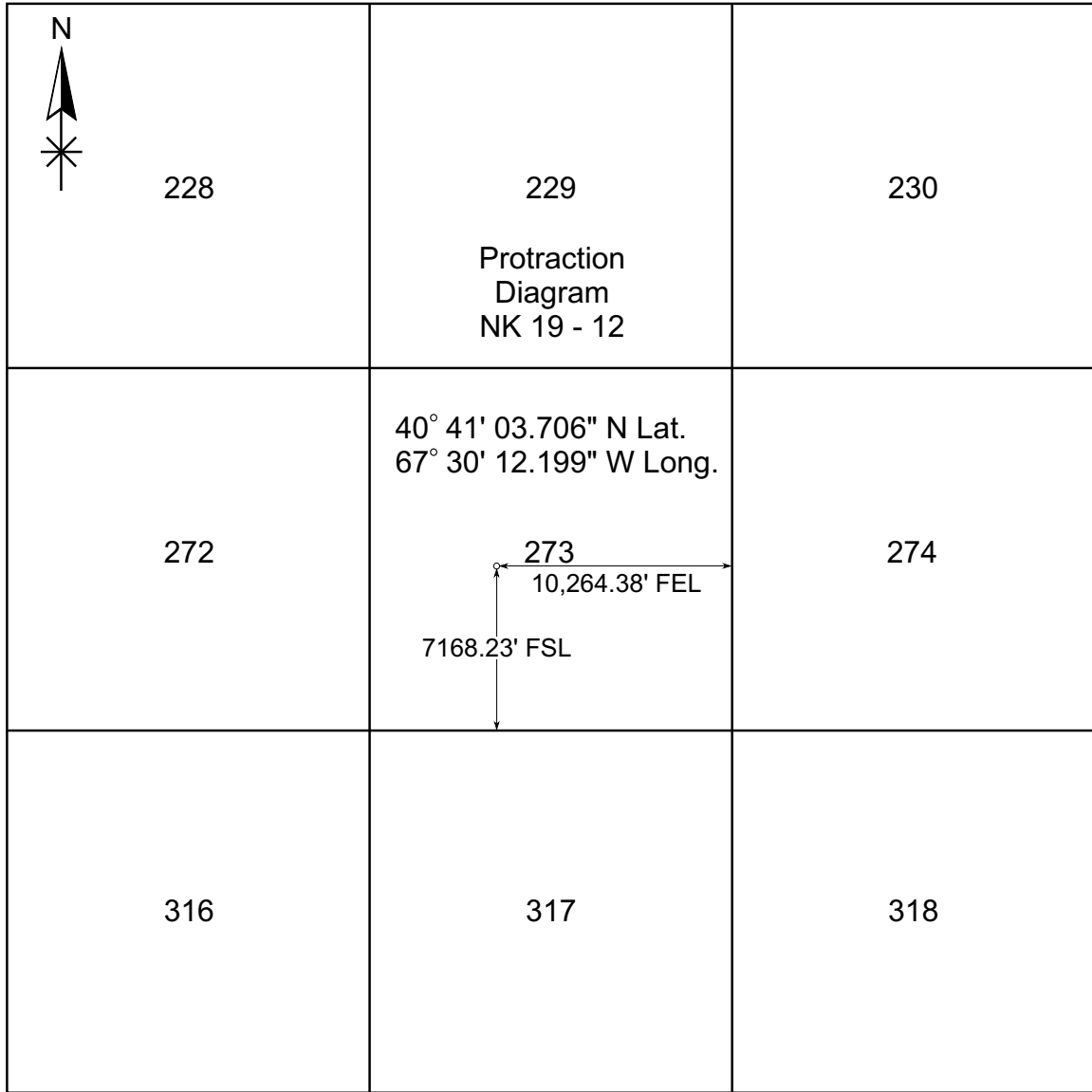

Figure 2. Location plat for the Mobil Block 273 No.1 well on the OCS Lydonia Canyon NK 19-12 protraction diagram.

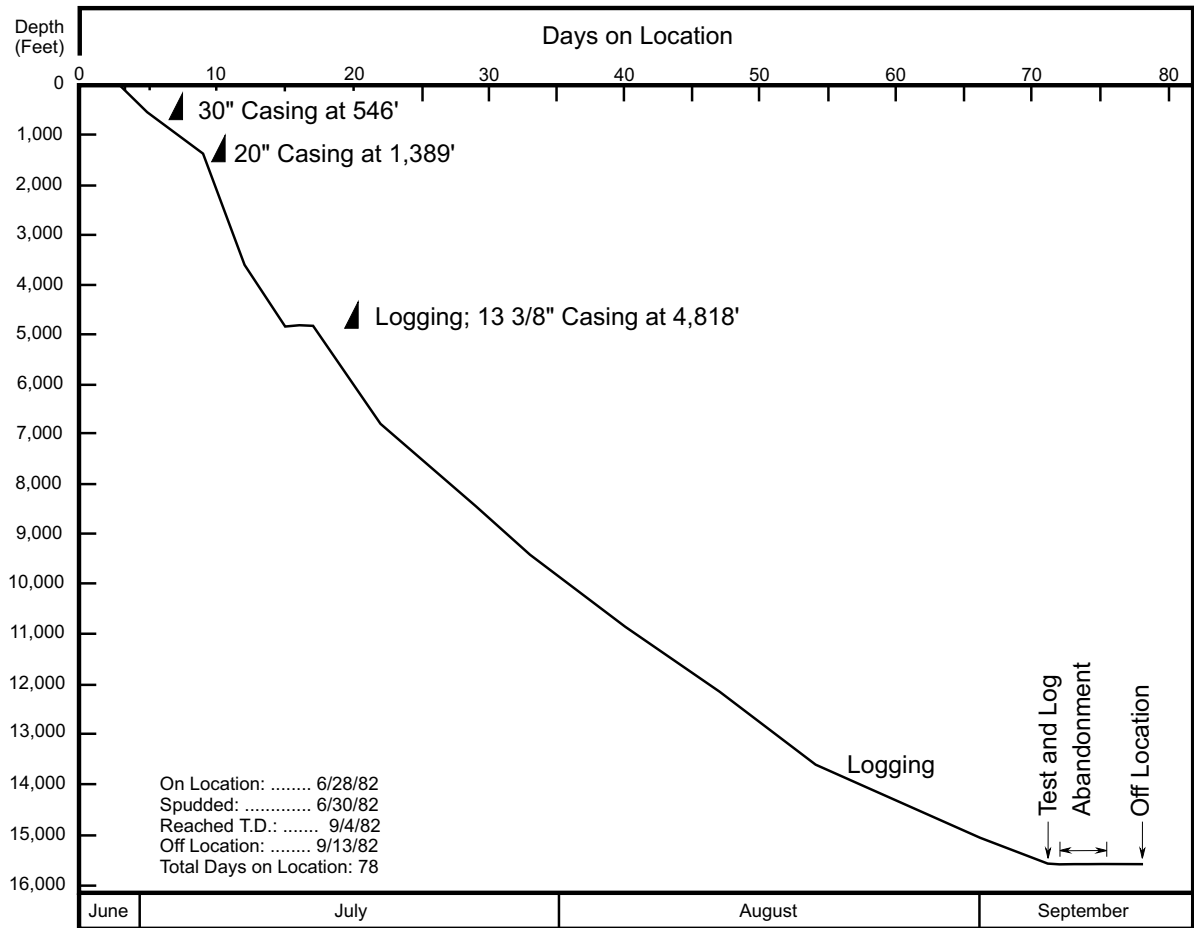

Figure 3. Daily drilling progress for the Mobil Lydonia Canyon Block 273 No. 1 well.

**Table 1. Well statistics**

Well identification:	API No. 61-040-00008 Lease No. OCS-A-0196
Surface location:	Lydonia Canyon NK 19-12 LC Block 273 7,168.23 feet FSL 10,264.38 feet FEL  Latitude: 40 <sup>o</sup> 41' 03.706" N Longitude: 67 <sup>o</sup> 30' 12.199" W  UTM coordinates: X = 626,471.41m Y = 4,504,584.88m
Bottomhole location:	21.6 feet N and 79.7 feet E of surface location
Proposed total depth:	19,500
Measured depth:	15,580
True vertical depth:	15,578.4
Kelly bushing elevation:	89 feet
Water depth:	301 feet
Spud date:	June 30, 1982
Reached TD:	September 7, 1982
Off location:	September 13, 1982
Final well status:	Plugged and abandoned

Note: All depths indicated in this report are measured from the kelly bushing, unless otherwise indicated. Mean sea level is the datum for the water depth.

and 200 sacks, respectively, of class H cement. The 13 3/8-inch casing was cut at 700 feet depth, and a 429- sack class H cement plug was set with its top at 514 feet depth (124 feet below mud line). The blowout preventer was retrieved, and

the 20-inch and 30-inch casings were cut 17 feet below the mudline and retrieved, together with the wellhead and guide base. An ocean-floor survey was performed, and the *Rowan Midland* left the Mobil LC Block 273 No. 1 well location on September 13, 1982.

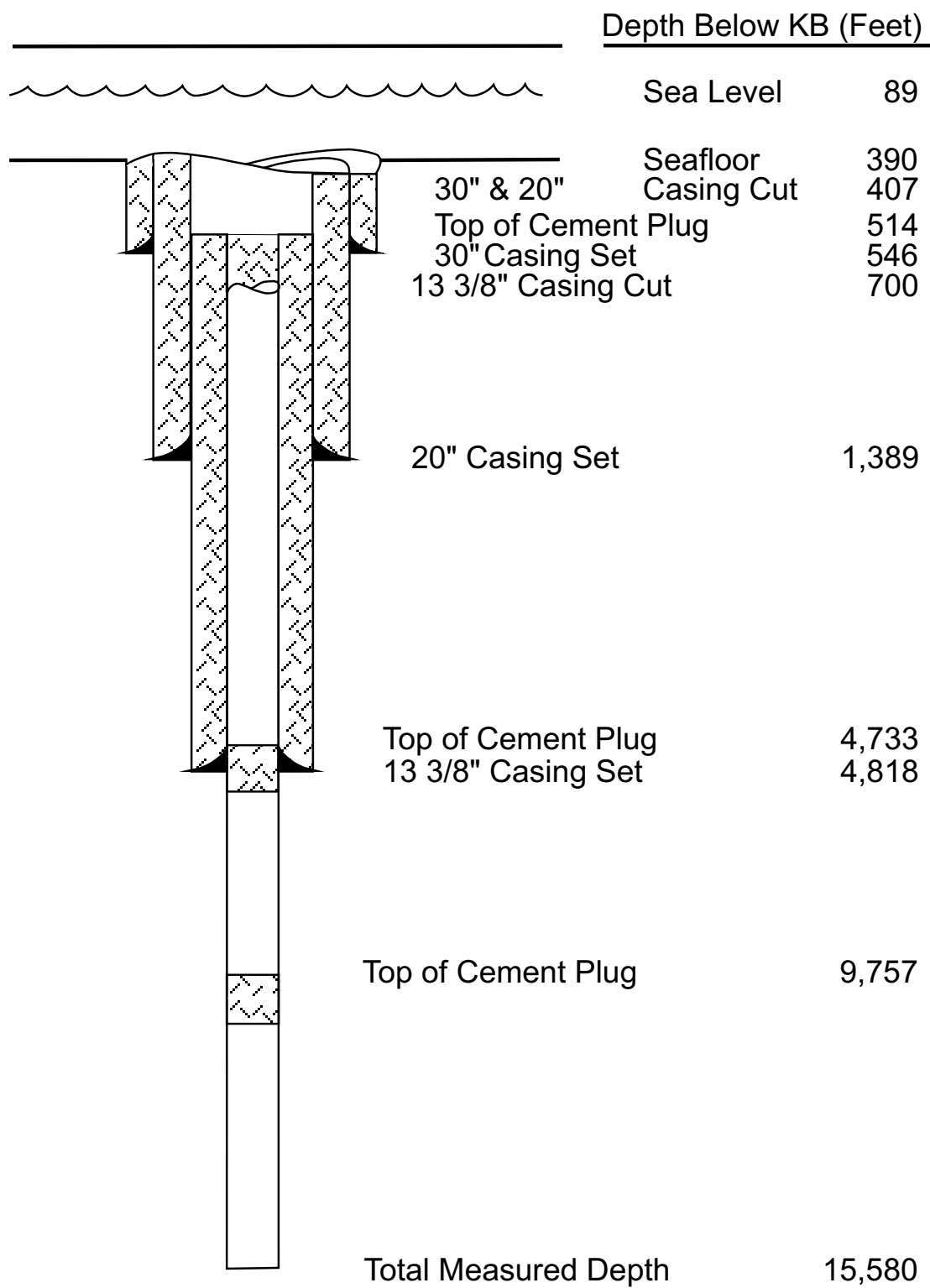

Figure 4. Casing diagram for the Mobil Lydonia Canyon Block 273 No. 1 well

## WELL VELOCITY PROFILE

Schlumberger, Ltd. Wireline Testing ran a velocity checkshot survey between 1,411 and 15,431 feet in the Mobil LC Block 273 No. 1 well. The checkshot data, together with that for the other nine wells drilled on Georges Bank, were given by MMS to Velocity Databank, Inc. at their request after all leases had been relinquished or had expired. Velocity Databank calculated interval, average, and

RMS velocities, plotted time-depth curves, and tabulated the data. Table 2 presents well depth, two-way travel time, and the calculated velocities for the Mobil LC Block 273 No. 1 well. Figures 5 and 6 show interval velocity, average velocity, and RMS velocity plotted against depth and against two-way travel time, respectively. Well depths are subsea.

**Table 2. Well velocity data**

<b>Depth</b>	<b>2-Way Time</b>	<b>Interval Velocity</b>	<b>RMS Velocity</b>	<b>Average Velocity</b>
1,411	0.496	5,689	5,689	5,689
2,361	0.784	6,597	6,038	6,022
3,611	1.090	8,169	6,705	6,625
4,841	1.344	9,685	7,361	7,203
6,121	1.582	10,756	7,965	7,738
6,881	1.704	12,459	8,367	8,076
7,911	1.872	12,261	8,787	8,451
8,741	2.002	12,769	9,099	8,732
9,401	2.100	13,469	9,348	8,953
9,891	2.166	14,848	9,563	9,132
9,971	2.176	15,999	9,602	9,164
10,361	2.232	13,928	9,734	9,284
10,951	2.300	17,352	10,043	9,522
11,561	2.374	16,486	10,304	9,739
12,131	2.434	19,000	10,605	9,967
12,381	2.464	16,666	10,699	10,049
12,826	2.510	19,347	10,919	10,219
13,421	2.574	18,593	11,174	10,428
13,661	2.604	15,999	11,242	10,492
13,931	2.630	20,769	11,375	10,593
14,441	2.678	21,250	11,626	10,784
14,801	2.714	19,999	11,776	10,907
15,111	2.744	20,666	11,909	11,013
15,431	2.776	19,999	12,033	11,117

A lithologic column is also shown in figure 5, and four velocity intervals are indicated, which generally correlate with

four lithologic intervals penetrated by the well (table 3).

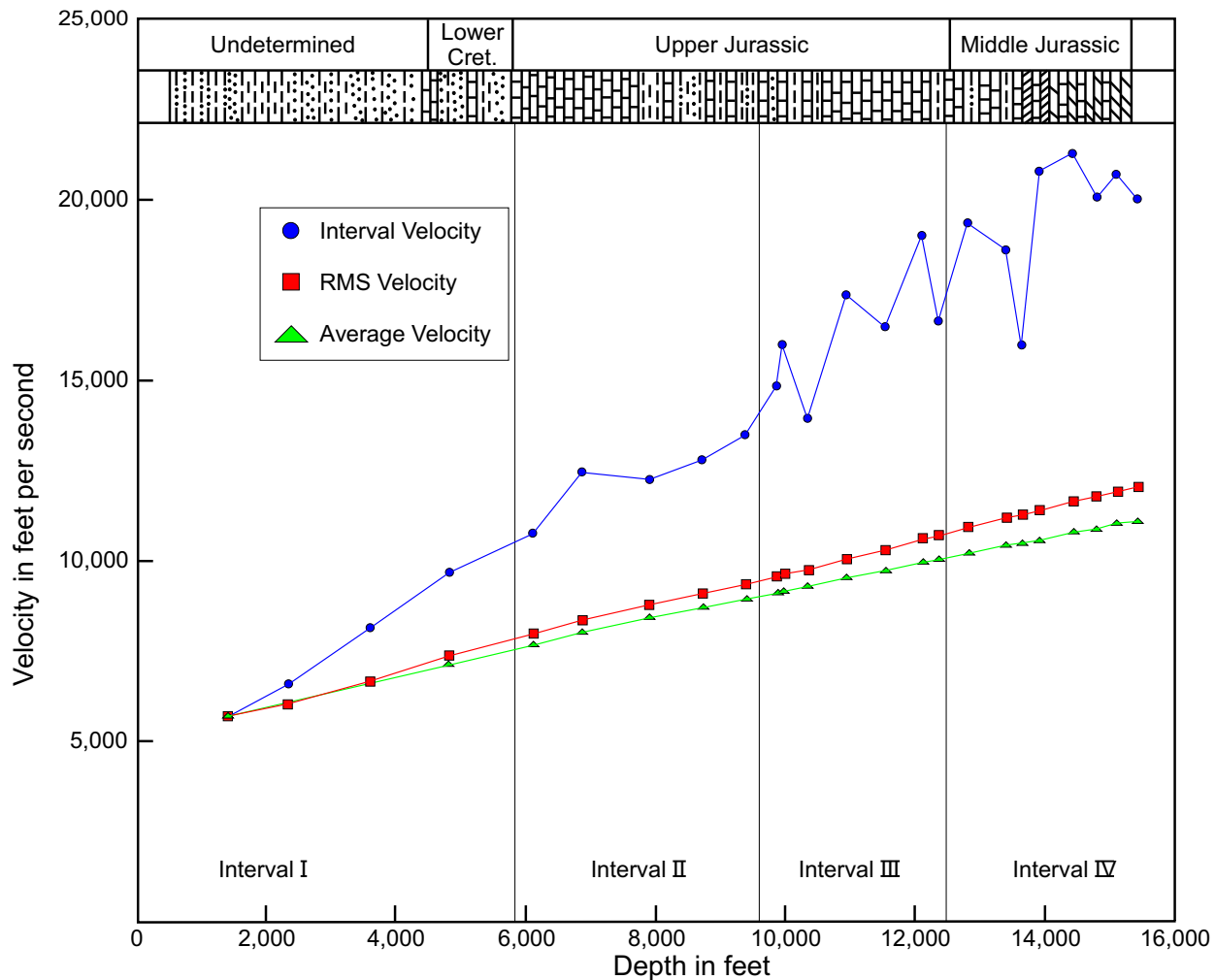

Figure 5. Well velocity profile for the Mobil Lydonia Canyon Block 273 No. 1 well, plotted against depth, with biostratigraphic ages and generalized lithologies. Intervals are explained in text.

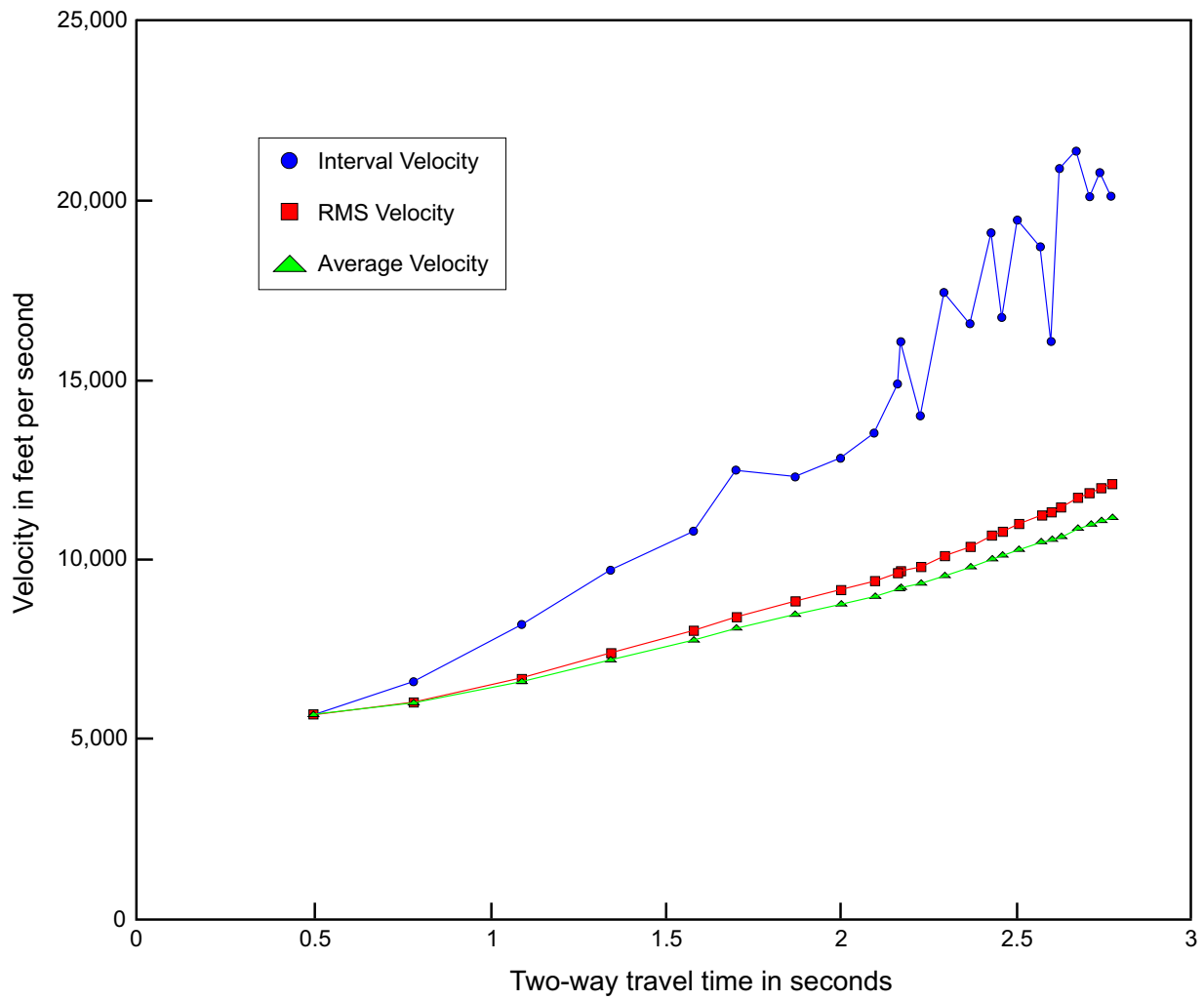

Figure 6. Well velocity profile for the Mobil Lydonia Canyon Block 273 No. 1 well, plotted against two-way travel time.

**Table 3. Well velocity intervals**

<b>Interval</b>	<b>Depth Range (feet)</b>	<b>Interval Velocity Range (feet/second)</b>	<b>Average Interval Velocity (feet/second)</b>
I	0-5,800	5,689-9,685	7,535
II	5,800-9,600	10,756-13,469	12,343
III	9,600-12,500	13,928-19,000	16,326
IV	12,500-15,431	15,999-21,250	19,578

**Interval I** This interval contains the first four data points and includes the entire column of water and rock to 5,800 feet. The low to moderate interval velocities increase with depth, reflecting the progression from water to unconsolidated sediment to lithified siliciclastic rocks to the presence of some limestone beds below 4,000 feet. The velocity increase is also a consequence of greater rock densities with accruing depth, an effect that continues through the following intervals. This interval is Lower Cretaceous in its lowermost 1,300 feet.

**Interval II** This interval is identified on the basis of intermediate interval velocities, which correlate with limestones. The lower portion of the interval contains siliciclastic interbeds,

which may lower the velocities somewhat. This interval is Upper Jurassic.

**Interval III** This interval is identified on the basis of interval velocities that are higher and more variable than the previous interval. The variability is likely a consequence of interbedded lithologies, but why this interval is more variable than the previous one is not apparent. Interval III is the lower portion of the Upper Jurassic series.

**Interval IV** This Middle Jurassic interval is identified on the basis of moderately high and high interval velocities that vary considerably in their magnitudes. For this interval, the variability is consistent with interbedded limestone, dolomite, anhydrite, and siliciclastics. This interval is Middle Jurassic.

## LITHOLOGIC INTERPRETATION

Taken and adapted from A. C. Giordano, MMS internal report

Samples were collected from 547 to 15,580 feet, total depth. Sample quality ranged from good to excellent. Thirty-two sidewall cores provided additional lithologic control. The following lithologic descriptions are from examination of drill cuttings, supplemented by thin sections of sidewall cores. Depths of lithologic boundaries are adjusted with reference to "electric" and "mud" logs. All depths are from kelly bushing. Rocks penetrated are divided into gross lithologic-stratigraphic units, and a lithologic column appears in figure 7.

From 547 to 620 feet, the section consists of medium- to fine-grained sand with abundant foraminifera, and from 620 to 1,330 feet, gray to green, very soft, noncalcareous mudstone. Dolomite-cemented, silty mudstone occurs from 700 to 1,000 feet. Foraminifera are abundant throughout the mudstones, along with shell fragments. Glauconite occurs from 1,300 to 1,330 feet, as in other Georges Bank wells at similar depths, perhaps indicating the Tertiary-Cretaceous unconformity. In the Mobil LC Block 273 well, the glauconite interval also contains lignite.

The uppermost 400 feet of the interval from 1,330 to 2,500 feet contains sand that grades downward into clay. The sand is medium grained, moderately well sorted, and unconsolidated with clear to milky-white grains that are subrounded to subangular. The clay is dark gray to green, very soft, sticky, and moderately calcareous. Foraminifera, glauconite, fossil

fragments (primarily Inoceramus prisms), and traces of feldspar, mica, and pyrite are present. This interval contains no evidence of oil staining or fluorescence.

The interval from 2,500 to 4,410 feet consists of sand, calcareous sandstone, claystone, shale, and limestone. The sand is white to light gray, moderately well to poorly sorted, and very fine to fine with subrounded to rounded grains. Abundant fossil fragments with trace glauconite, lignite, and pyrite are present. The calcareous sandstone is gray, very fine to fine, moderately well sorted and well cemented, with some secondary visible porosity. The claystone is light to dark gray, soft, sticky, and silty, and grades to shale. The lowermost 150 feet of the interval is calcareous shale that grades downward into marly gray limestone. The entire interval contains no evidence of oil staining and no cut; minor mineral fluorescence occurs between 2,500 and 2,600 feet.

The interval from 4,410 to 5,820 feet consists of sand, shale, and limestone. The sand is unconsolidated, milky white to clear, and has medium to very coarse, subangular to subrounded grains. The shale is gray to dark gray, noncalcareous, and silty. The limestone is light gray to gray and microcrystalline with fossil fragments, pellets, and ooids and shows some dolomite and anhydrite replacement. There are also minor grainstones and wackestones present. No oil staining but minor mineral fluorescence is indicated on the mud log.

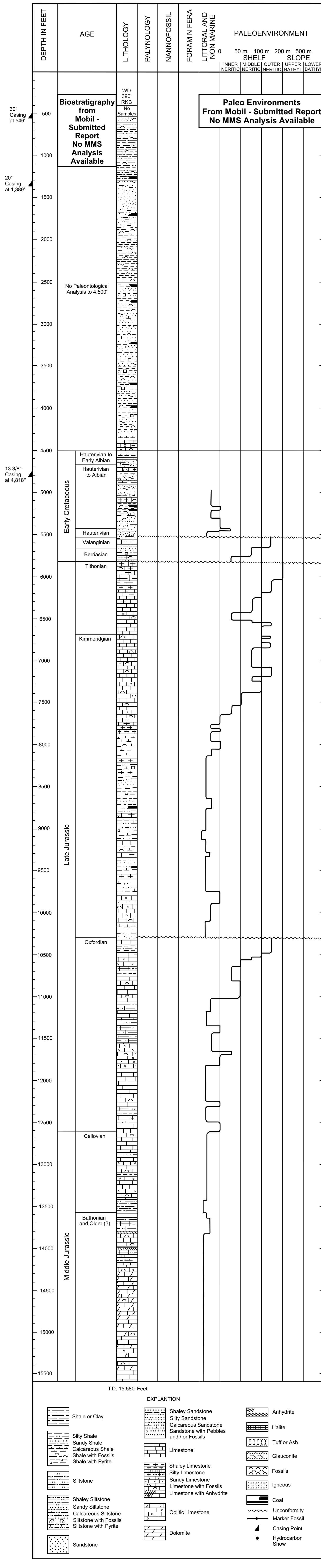

Figure 7. Columnar chart of the lithology, biostratigraphy, and paleobathymetry of the Mobil Lydonia Canyon Block 273 No. 1 well. Lithologic interpretations from examination of cuttings; lithologic breaks picked from well logs. Stage tops and paleobathymetry from Mobil.

The interval from 5,820 to 10,400 feet consists of limestone in the upper 2,000 feet that becomes increasingly shaley and silty with increasing depth and grades into the underlying sandstones, siltstones, and shales that comprise the lower part of the interval. The limestone is white, tan or light to dark gray, microcrystalline to microsucrosic, firm to hard, variably oolitic, and chalky. The shales and siltstones are light to dark gray and calcareous and contain pyrite, mica, lignite, glauconite, and fossil fragments. Present also is white to light-gray, friable to moderately hard, calcareous, shaley siltstone and very fine sandstone. Throughout the interval visible porosity is poor. Recrystallized quartz and minor dolomite fill oolitic secondary porosity partly to totally. No oil staining but some yellow and orange mineral fluorescence is indicated on the mud log.

The section from 10,400 to 14,200 feet consists of limestone, thinly bedded siltstone, and numerous shale interbeds. The limestone is light to dark gray or brown, moderately hard to brittle, microcrystalline to microsucrosic and, in places, chalky. Some portions are oolitic with secondary, interpartical porosity filled with recrystallized quartz. Some micritic portions are altered to chicken-wire anhydrite or dolomite. Fossil fragments

are also present. Parts of the section are thinly interbedded with a gray to dark brown, firm to moderately hard, and noncalcareous siltstone. From 13,420 to 13,570 feet, red to brown to gray, soft to moderately hard, silica-cemented siltstone is present. Interbedded shale is gray, silty, and noncalcareous, containing trace pyrite, glauconite, and lignite. Traces of mica, very-fine sandstone, shale, lignite, and anhydrite are also present throughout the interval. No oil staining, but some gold and yellow mineral fluorescence, is indicated on the mud log.

The section from 14,200 to 15,580 feet (TD) consists of dolomite with limestone interbeds and subordinate anhydrite. The dolomite is light gray to brown, coarse to fine grained, moderately hard, and slightly argillaceous to silty. The dolomite becomes coarser grained with increasing depth. The limestone is light to dark gray to brown, soft to moderately hard, microsucrosic to microcrystalline, argillaceous, slightly silty, dolomitic, and oolitic. Anhydrite occurs as thin interbeds and as disseminated mineralization among the carbonates. Well logs suggest abundant, thin shale interbeds throughout the section. Orange, yellow, and gold mineral fluorescence is noted on the mud log with no oil staining indicated.

## BIOSTRATIGRAPHY

This biostratigraphic and paleoenvironmental summary is taken from a report submitted by Mobil to MMS for the Mobil LC Block 273 No. 1 well. No MMS paleontological interpretations

are available. Biostratigraphy and a more detailed depositional environmental presentation, from an illustration in Mobil's report, appear in table 4 and figure 7.

**Table 4. Biostratigraphy and depositional environments**

Series	Stage	Depth Interval (feet)	Environment of Deposition
	Not examined	0-4,500	
Lower Cretaceous	Hauterivian to early Albian	4,500-4,680	
	Hauterivian to Aptian	4,680-5,430	Littoral (4,950-5,160) Littoral/inner neritic (5,160-5,190) Littoral to brackish (5,190-5,310) Littoral/inner neritic (5,310-5,430)
	Hauterivian Unconformity 5,520	5,430-5,520	Inner neritic (5,430-5,460) Littoral/supralittoral (5,460-5,520)
	Valanginian	5,520-5,670	Outer neritic (5,520-5,640) Middle neritic (5,640-5,670)
	Berriasian Unconformity 5,820	5,670-5,820	Middle neritic (5,670-5,760) Inner neritic (5,760-5,820)
Upper Jurassic	Tithonian	5,820-6,690	Outer, middle, inner neritic (5,820-6,510) Inner, middle, outer neritic (6,510-6,690)
	Kimmeridgian Unconformity 10,290	6,690-10,290	Outer to middle neritic (6,690-8,070) Littoral to supralittoral (8,070-10,290)
	Oxfordian	10,290-12,580	Outer neritic (10,290-10,470) Littoral/supralittoral (11,190-11,370) Fluctuating middle neritic and supralittoral (11,370-12,580)
Middle Jurassic	Callovian	12,580-13,570	Littoral to inner neritic (12,580-12,610) Littoral/supralittoral (12,610-13,420)
	Bathonian, Possibly older	13,570-15,580 (TD)	Littoral to supralittoral, brackish to fresh (13,630-13,840)

# FORMATION EVALUATION

Taken and adapted from R. Nichols, MMS internal report

Schlumberger Ltd. ran the following geophysical “electric” logs in the Mobil Lydonia Canyon (LC) Block 273 No. 1 well to provide information for

stratigraphic correlation and for evaluation of formation fluids, porosity, and lithology:

**Table 5. Well logs**

Log Type	Depth Interval (feet) below KB
DISFL/Sonic (dual induction spherically focussed log/sonic)	1,389-15,548
CNL/FDC (compensated neutron log/compensated formation density)	1,389-15,553
HDT (high resolution dipmeter)	4,813-15,552

Exploration Logging, Inc. provided a formation evaluation “mud” log that includes a rate of penetration curve, sample description, and a graphic presentation of any hydrocarbon shows encountered (550 to 15,580 feet). In addition, a drilling data pressure log (550 to 15,580 feet) was run as well as a pressure evaluation log (550 to 15,580 feet).

The “electric” logs, “mud” log, and other available data were analyzed in detail to determine the thickness of potential reservoirs, average porosities, and feet of hydrocarbon present. Reservoir rocks with porosities less than 5 percent were disregarded. A combination of logs was used in the analysis, but a detailed lithologic and reservoir property determination from samples, conventional cores, and sidewall cores, in addition to full consideration of any test results, is necessary to substantiate the following estimates shown in table 6.

The electric logs are of inferior quality, apparently because of poor hole condition. Washouts, indicated on the caliper log, are severe from 5,500 to 6,200, 6,500 to 9,900, and 10,800 to 15,548 feet and appear to have adversely affected the density and the neutron porosity readings. In addition, the medium-reading induction log records a false annulus (medium reading less than the deep reading) from 13,900 to 15,548 feet. On run 2 from 4,813 to 14,095 feet, the medium-reading induction curve was not working. A number of SP shifts are present on the log at 11,430, 11,500, 11,530, 11,610, 12,700, 13,350, 13,610, 13,660, and 13,900 feet. The SP is extremely cyclic on runs 1 and 2.

The only sidewall core data available are from a wellsite description, summarized in table 7. No petrographic analysis was done. Sixty-four cores were attempted, and 32 were successful. The qualitative sidewall core porosity descriptions compare favorably to the porosities calculated from the sonic log except for

**Table 6. Well log interpretation summary**

<b>Series<sup>1</sup></b>	<b>Depth Interval (feet)</b>	<b>Feet of Potential Reservoir<sup>2</sup></b>	<b>Average Porosity</b>	<b>Water Saturation (%)</b>
	2,504-2,528	22	35	NC*
	2,654-2,728	48	35	NC
	2,782-2,794	12	35	NC
	2,840-2,886	41	35	NC
	2,932-2,948	16	35	NC
	3,550-3,618	57	35	NC
	3,938-3,950	12	35	NC
	4,006-4,070	64(?)	20	NC
EK	4,618-4,690	54	35	NC
	4,711-4,724	13	35	NC
	4,776-4,794	18	35	NC
	4,807-4,846	25	35	NC
	4,901-4,964	61	28	NC
	5,052-5,092	35	29	NC
	5,218-5,229	11	35	NC
	5,274-5,289	15	32	NC
	5,332-5,365	29	35	NC
	5,465-5,494	27	33	NC
UJ	8,328-8,342	12	18	NC
	8,377-8,388	11	19	NC
	8,424-8,456	29	21	NC
	8,530-8,545	15	21	NC
	8,630-8,642	12(?)	25	NC
	9,198-9,222	22	16	NC
	9,424-9,434	10	15	NC
	9,904-9,952	29	13	31 <sup>3</sup>
	9,978-9,994	10	7	NC
	11,472-11,498	14	14	NC
	11,796-11,820	4	5	NC
MJ	13,034-13,048	4(?)	5	NC
	13,283-13,313	13	8	NC
	13,360-13,375	11	12	NC
	13,578-13,594	8	7	NC
	13,865-13,921	10	7	19(?) <sup>4</sup>
	14,203-14,206	3	5	NC
	14,420-14,442	4	6	5(?) <sup>5</sup>

*continued*

**Table 6. Well log interpretation summary--continued**

Series <sup>1</sup>	Depth Interval (feet)	Feet of Potential Reservoir <sup>2</sup>	Average Porosity	Water Saturation (%)
MJ	14,501-14,504	3	6	NC
	14,544-14,584	10	7	NC
	14,633-14,714	15	6	NC
	14,784-14,860	19	6	34(?) <sup>6</sup>
	15,014-15,038	11	10	NC
	15,199-15,204	2	5	NC
	15,256-15,272	2	5	NC

\*Not calculated

<sup>1</sup>From company-submitted paleontology report

<sup>2</sup>Generally in beds > 10 feet thick and ? > 5%

<sup>3</sup>Carbonate PRI (production ratio index) of > 0.04 indicates primarily water production from this interval, Total Gas = 38 units

<sup>4</sup>Thinly bedded, out-of-gauge hole, questionable SP, Total Gas = 38 units

<sup>5</sup>Thinly bedded, out-of-gauge hole, questionable SP, Total Gas = 33 units

<sup>6</sup>Thinly bedded, out-of-gauge hole, questionable SP, Total Gas = 32 units

**Table 7. Sidewall core summary**

Depth Interval (feet)	Lithology	Porosity Range (%)	Permeability Range (MD)*
4,968-5,628	Sandstone	Good	-
5,728-8,180	Limestone	Poor-tight	-
8,856-9,820	Sandstone/Limestone	Poor	-
9,922-12,345	Limestone	No visible porosity	-
14,310-15,525	Dolomite/Limestone	Tight	-

\*Not included in operator's description

the interval 8,856 to 9,820 feet, where the sonic log indicated fair porosities in two thin zones.

No conventional cores were taken in this well.

Results of the high-resolution dipmeter survey were recorded on an arrow plot from 4,813 to 15,552 feet. Possible structural anomalies may be present at 5,270, 8,500(?), 10,030, 10,150, 13,690, and 14,100 feet.

Dip directions and magnitudes are summarized in table 8.

Table 9 lists all shows of hydrocarbon encountered in the well. None of the shows is judged to be significant.

Exploration Logging of USA, Inc., reported that pore pressure remained near 0.44 psi/foot to a depth of 14,000 feet. Below 14,000 feet, dxc values decreased, indicating a rise in pore pressure to 0.494 psi/foot (9.5 ppg, EQMW) at total depth,

**Table 8. Dipmeter data summary**

<b>Depth Interval (feet)</b>	<b>Direction</b>	<b>Magnitude</b>
4,850-5,550	Southwest	0-8 <sup>0</sup>
5,550-8,500	West	0-12 <sup>0</sup>
8,500-10,030	Southwest	0-14 <sup>0</sup>
10,030-10,150	West	1-20 <sup>0</sup>
10,150-10,350	South	1-22 <sup>0</sup>
10,350-13,690	Southwest	0-12 <sup>0</sup>
13,690-14,100	West	0-13 <sup>0</sup>
14,100-15,552	West	1-44 <sup>0</sup>

15,580 feet. An increase in delta chloride can be seen at 14,490 feet. The mud

weight was raised to 10.8 ppg at 14,400 feet and to 10.9 ppg at total depth. No formation tests were run in this well.

**Table 9. Hydrocarbon shows**

Depth (Feet)	Drilling Break (Minutes/Foot)	Sample Description (Mud Log)	Total Gas bk. grd.		Chromatograph	Cuttings Gas	Conventional Cores	Sidewall Cores		Well Log Interpretation		Tests
								φ		φ	Sw	
9,910 - 9,940	2 - 6	LS, hd NVP min flu, no cut	2	38	C <sub>1,2,3</sub>	-	-	9,918 NVP 9,922 NVP 9,940 NVP		9,905-9,952	13 31	-
11,475 - 11,490	3 - 7	Sltstn, calc, NVP no flu, no cut	2	6	C <sub>1,2,3</sub>	-	-	-		11,472-11,498	14	-
11,810 - 11,820	5 - 6	SS, hd, br yel min flu, tr yel-wh strm cut	2	4	C <sub>1,2,3,4i</sub>	-	-	-		11,796-11,820	5	-
12,820 - 12,980	4 - 6	LS, hd, NVP, min flu, no cut	2	3	C <sub>1,2,3</sub>	-	-	-		-		-
13,050 - 13,070	3.5 - 5	LS, hd, NVP, no flu, no cut	2	6	C <sub>1,2,3,4i</sub>	-	-	-		13,034-13,048	5	-
13,290 - 13,320	-	LS, min flu, no cut	2	2	C <sub>1,2,3</sub>	-	-	-		13,283-13,313	8	-
13,860 - 13,940	-	LS, hd, min flu, no cut	2	35	C <sub>1,2,3,4</sub>	-	-	-		13,865-13,921	7 19	-
14,210 - 14,230	-	DOL, hd, min flu, no cut	2	7	C <sub>1,2,3,4i-n</sub>	-	-	-		14,203-14,206	5	-
14,430 - 14,450	-	DOL, hd, min flu, no cut	3	33	C <sub>1,2,3,4i-n</sub>	-	-	14,415 tt 14,443 tt		14,420-14,442	6 5	-
14,500 - 14,510	-	DOL, hd, min flu, no cut	3	10	C <sub>1,2,3,4i-n</sub>	-	-	14,530 tt		14,501-14,504	6	-
14,550 - 14,600	-	DOL, hd, min flu, no cut	3	8	C <sub>1,2,3,4i-n</sub>	-	-	-		14,544-14,584	7	-
14,780 - 14,870	7 - 10	DOL / LS, min flu, no cut	3	32	C <sub>1,2,3,4i-n</sub>	-	-	-		14,784-14,860	6 34	-
15,025 - 15,040	-	LS, min flu, no cut	4	10	C <sub>1,2,3,4i-n</sub>	-	-	-		15,014-15,038	8	-
15,195 - 15,205	-	DOL, min flu, no cut	4	12	C <sub>1,2,3,4n</sub>	-	-	15,200 tt		15,199-15,204	5	-
15,260 - 15,280	-	DOL, min flu, no cut	3	6	C <sub>1,2,3,4n</sub>	-	-	-		15,256-15,272	5	-

NVP = no visible porosity; tt = tight

## GEOHERMAL GRADIENT

Figure 8 shows bottomhole temperatures for three logging runs in the Mobil LC Block 273 No.1 well plotted against depth. A temperature of 60 °F is assumed at the seafloor at an indicated depth of 390 feet (301-foot water depth plus 89-foot kelly bushing elevation). Shown also is a

straight-line graph between the seafloor and total-depth temperatures in order to represent an overall geothermal gradient for the well, which is 1.22 °F/100 ft. Calculated geothermal gradient for all Georges Bank wells ranges from 1.06 to 1.40 °F/100 ft.

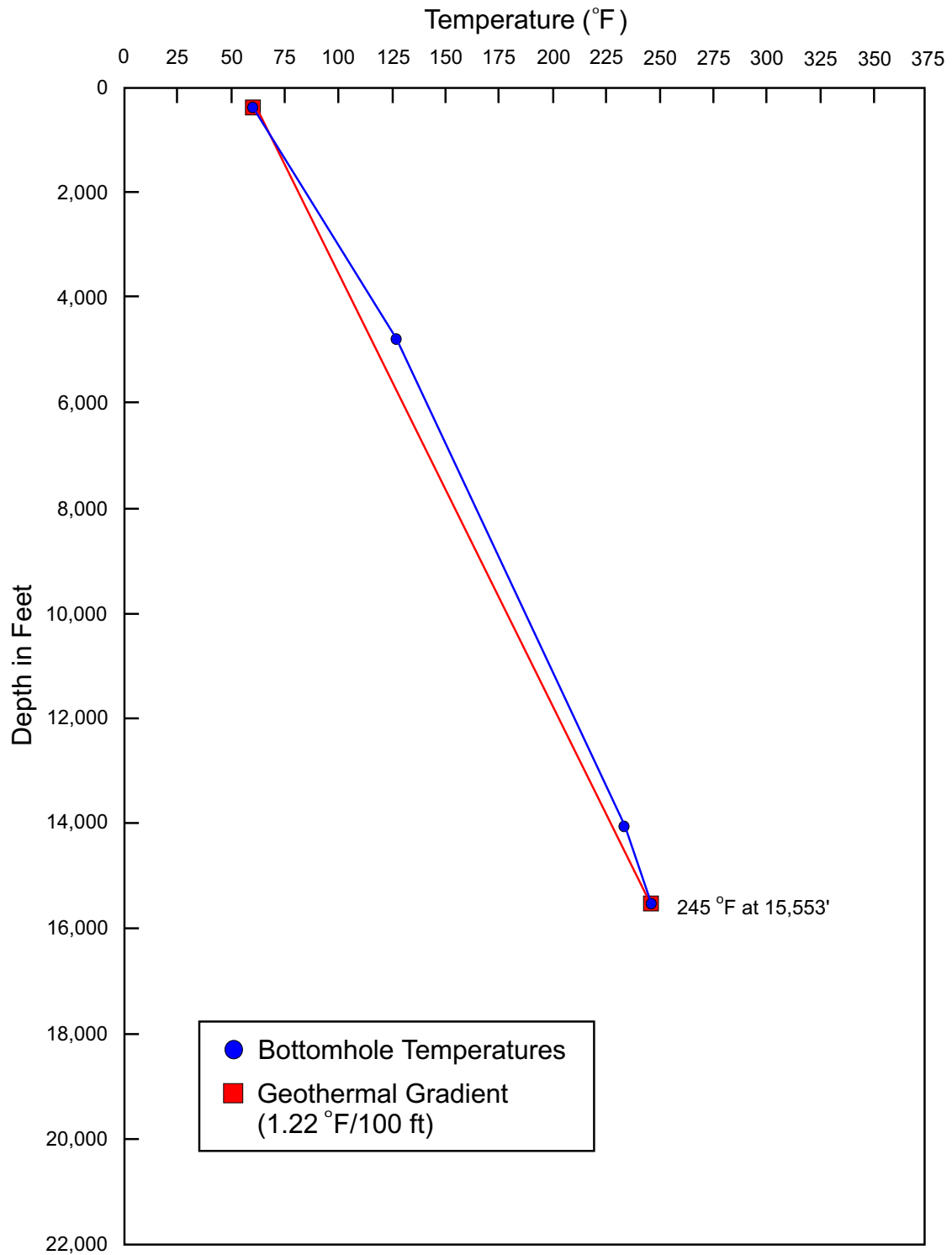

Figure 8. Well temperatures and geothermal gradient for the Mobil Lydonia Canyon Block 273 No. 1 well. Well temperatures from bottomhole temperatures of logging runs. Geothermal gradient based on bottomhole temperature of deepest logging run.

## KEROGEN ANALYSIS

Taken and adapted from C. E. Fry, MMS internal report

Kerogen type and thermal rank were determined by microscopic examination of kerogen slides and palynology slides made from drill cutting samples from the Mobil LC Block 273 No. 1 well. In this analysis, organic material is classified as one of four major types: algal-amorphous, organic material of marine origin, either recognizable algae or the unstructured remains of algal material; herbaceous, leafy portions of plants, including spores and pollen; woody, plant detritus with a lignified, ribbed structure; coaly, black opaque material, thought to be chemically inert. Visual estimates are made for the percentage of each type relative to the total abundance of kerogen contained in each of the slides. Algal material is generally considered the best source for oil; more structured terrestrial kerogen is primarily a gas source.

Thermal maturity of the organic material is estimated by comparing the color of various palynomorphs contained in the kerogen slides to the thermal alteration index (TAI) scale (figure 9) taken from Jones and Edison (1978). The colors displayed by the organic matter are an indication of the degree to which the kerogen has been thermally altered (Staplin, 1969).

Kerogen type and thermal alteration rank can be used with total organic carbon (TOC) abundance to evaluate whether sedimentary units are prospective as petroleum source rocks.

### KEROGEN TYPE

No cuttings samples are available above 550 feet in this well. MMS did kerogen analysis on 90-foot composited samples from 550 to 15,420 feet (TD is 15,580 feet). However, MMS did no biostratigraphic analysis. Geologic series, as well as the total organic carbon data cited herein, are from a biostratigraphic and geochemistry report submitted to MMS by Mobil. The company's analyses are only for samples from 4,500 feet to total depth.

Kerogen analysis results are shown in figure 10 and table 10. In general, algal plus herbaceous kerogen relative abundances decrease with increasing well depth, woody kerogens remain rather constant, and coaly organic matter increases with greater well depth. Algal kerogens are nearly absent below 10,630 feet. These kerogen abundances, relative to depth, are similar to results from other Georges Bank wells.

### MATURITY

Judging thermal maturity from well cuttings must be done with care to ensure that the material being analyzed is indigenous to the level sampled. Caved or reworked material will give false indications of maturity. Oxidation caused by a high energy environment of deposition can also alter the appearance of organic material. The thermal maturity of kerogen contained in the Mobil LC Block 273 No. 1 well was estimated by

Coal Rank	% Ro.	TAI	Spore Color	Principal Zones of Hydrocarbon Generation
Peat		1.0	Very Pale Yellow	Immature
Lignite		2.0	Pale Yellow	
			Yellow	
			Yellow-Orange	
Sub-Bituminous				
C	0.5	2.5	Orange-Brown	Oil
B				
A				
High Volatile Bituminous				
Medium Volatile Bituminous			Reddish-Brown	Condensate and Wet Gas
			Dark Reddish-Brown	
Low Volative Bituminous	1.5	3.5	Dark Brown	Dry Gas
Semi - Anthracite	2.0	3.7		
Anthracite	2.5			
	3.0			
	3.5			
	4.0	4.0	Black	

Figure 9. Relationships among coal rank, percent R<sub>o</sub>, TAI, spore color, and thermal zones of hydrocarbon generation (after Jones and Edison, 1978).



**Table 10. Relative kerogen abundances**

Series	Depth (feet)	Algal Range % (Ave %)	Herbaceous Range % (Ave %)	Woody Range % (Ave %)	Coaly Range % (Ave %)
Indet.	550-4,500	0-40 (18.82)	10-35 (26.47)	20-50 (31.47)	10-50 (23.24)
LK	4,500-5,820	5-40 (22.50)	20-35 (25.00)	20-40 (31.67)	20-25 (20.83)
UJ	5,820-12,580	0-25 (9.13)	20-35 (29.25)	20-40 (25.81)	20-45 (35.81)
MJ	12,580-15,580 (TD)	0-5 (1.00)	15-25 (22.00)	35-40 (36.00)	35-45 (41.00)

the visual observation of palynomorph color (figure 10). Because open-hole drilling was used for most of the well (4,818 feet to TD, 15,580 feet), there is a great deal of sample cuttings contamination by shallower, younger material. Indigenous palynomorphs indicating borderline maturity (2.6 TAI) first occur at 9,450 feet (Upper Jurassic, according to Mobil; table 4). Upper and Middle Jurassic samples (11,550 to 13,400 feet) contain palynomorphs with TAI values of 2.7, indicating greater thermal alteration. Near-peak values (2.9 TAI) were observed in the 13,380-foot sample, which is Middle Jurassic, according to Mobil's paleontological interpretation. Most of the organic material observed from 15,060 to 15,420 feet was extensively decomposed.

### ORGANIC RICHNESS

Total organic carbon (TOC) analysis by Mobil (figure 10, table 11) indicates that rocks penetrated by the Mobil LC Block

273 No. 1 well are organically lean, with most samples containing less than 1 percent TOC. The richest samples occur above 8,000 feet in Lower Cretaceous and upper Upper Jurassic rocks, but only two samples contain greater than 1 percent TOC (2 percent at 5,160 feet and 1.02 percent at 5,190 feet). Below 8,000 feet, rocks decrease in organic carbon content. The Middle Jurassic section has TOC values of 0.2 percent or less.

### CONCLUSION

Lower Cretaceous and biostratigraphically undetermined rocks, from 550 to 5,820 feet, have the largest proportion of algal kerogens and are therefore the most oil prone of the strata penetrated by the well. However, this shallower interval is organically lean and is thermally immature for the generation of hydrocarbons. The first evidence of mature TAI values (2.6 TAI) occurs at 9,450 feet in the Upper Jurassic system.

**Table 11. Total organic carbon analysis**

<b>Depth</b>	<b>TOC %</b>
4.500	0.27
4.530	0.31
4.560	0.37
4.590	0.09
4.620	0.00
4.650	0.10
4.680	0.10
4.710	0.09
4.740	0.06
4.770	0.09
4.800	0.11
4.830	0.52
4.860	0.77
4.890	0.35
4.920	0.00
4.950	0.20
4.980	0.59
5.010	0.42
5.040	0.29
5.070	0.13
5.100	0.61
5.130	0.81
5.160	2.00
5.190	1.02
5.220	0.84
5.250	0.71
5.280	0.00
5.310	0.24
5.340	0.17
5.370	0.36
5.400	0.25
5.430	0.67
5.460	0.30
5.490	0.31
5.520	0.19
5.550	0.00
5.580	0.16
5.610	0.10
5.640	0.10
5.670	0.09
5.700	0.11
5.730	0.10
5.760	0.11
5.790	0.17

*continued*

*continued*

<b>Depth</b>	<b>TOC%</b>
5.820	0.16
5.850	0.20
5.880	0.26
5.910	0.27
5.940	0.35
5.970	0.33
6.000	0.32
6.030	0.28
6.060	0.28
6.090	0.22
6.120	0.21
6.150	0.20
6.180	0.19
6.210	0.20
6.240	0.13
6.270	0.14
6.300	0.19
6.330	0.19
6.360	0.18
6.390	0.19
6.420	0.18
6.450	0.16
6.480	0.24
6.510	0.28
6.540	0.30
6.570	0.31
6.600	0.31
6.630	0.40
6.660	0.43
6.690	0.26
6.720	0.33
6.750	0.32
6.780	0.37
6.810	0.36
6.840	0.50
6.870	0.41
6.900	0.42
6.930	0.29
6.960	0.28
6.990	0.30
7.020	0.32
7.050	0.37
7.080	0.32

*continued*

*continued*

<b>Depth</b>	<b>TOC %</b>
7.110	0.34
7.140	0.36
7.170	0.38
7.200	0.55
7.230	0.46
7.260	0.52
7.290	0.55
7.320	0.43
7.350	0.47
7.380	0.40
7.410	0.36
7.440	0.38
7.470	0.43
7.500	0.59
7.530	0.61
7.560	0.52
7.590	0.57
7.620	0.53
7.650	0.79
7.680	0.68
7.710	0.64
7.740	0.63
7.770	0.86
7.800	0.82
7.830	0.85
7.860	0.81
7.890	0.80
7.920	0.76
7.950	0.72
7.980	0.80
8.010	0.68
8.040	0.55
8.070	0.58
8.100	0.58
8.130	0.71
8.160	0.42
8.190	0.34
8.220	0.35
8.250	0.34
8.280	0.33
8.310	0.33
8.340	0.38
8.370	0.34

*continued*

**Table 11. Total organic carbon analysis--*continued***

<b>Depth</b>	<b>TOC %</b>
8,400	0.42
8,430	0.43
8,460	0.45
8,490	0.72
8,520	0.50
8,550	0.97
8,580	0.77
8,610	0.59
8,640	0.45
8,670	0.53
8,700	0.00
8,730	0.69
8,760	0.57
8,790	0.54
8,820	0.52
8,850	0.48
8,880	0.47
8,910	0.34
8,940	0.46
8,970	0.39
9,000	0.39
9,030	0.39
9,060	0.42
9,090	0.39
9,120	0.37
9,150	0.43
9,180	0.35
9,210	0.41
9,240	0.41
9,270	0.40
9,300	0.44
9,330	0.43
9,360	0.38
9,390	0.42
9,420	0.47
9,450	0.46
9,480	0.38
9,510	0.41
9,540	0.35
9,570	0.33
9,600	0.31
9,630	0.34
9,660	0.36
9,690	0.38

*continued*

*continued*

<b>Depth</b>	<b>TOC %</b>
9,720	0.35
9,750	0.41
9,780	0.45
9,810	0.40
9,840	0.32
9,870	0.28
9,900	0.30
9,930	0.22
9,960	0.20
9,990	0.21
10,020	0.18
10,050	0.20
10,080	0.22
10,110	0.23
10,140	0.24
10,170	0.18
10,200	0.33
10,230	0.19
10,260	0.18
10,290	0.22
10,320	0.34
10,350	0.50
10,380	0.57
10,410	0.61
10,440	0.46
10,470	0.27
10,500	0.23
10,530	0.17
10,560	0.24
10,590	0.22
10,620	0.18
10,650	0.17
10,680	0.18
10,710	0.18
10,740	0.17
10,770	0.15
10,800	0.17
10,830	0.17
10,860	0.17
10,890	0.16
10,920	0.19
10,950	0.21
10,980	0.16

*continued*

*continued*

<b>Depth</b>	<b>TOC %</b>
11,010	0.15
11,040	0.15
11,070	0.16
11,100	0.16
11,130	0.16
11,160	0.17
11,190	0.18
11,220	0.16
11,250	0.21
11,280	0.20
11,310	0.20
11,340	0.23
11,370	0.24
11,400	0.23
11,430	0.23
11,460	0.17
11,490	0.19
11,520	0.16
11,550	0.16
11,580	0.16
11,610	0.24
11,640	0.22
11,670	0.25
11,700	0.20
11,730	0.12
11,760	0.13
11,790	0.12
11,820	0.12
11,850	0.10
11,880	0.10
11,910	0.11
11,940	0.09
11,970	0.09
12,000	0.09
12,030	0.09
12,060	0.10
12,090	0.09
12,120	0.12
12,150	0.13
12,180	0.13
12,210	0.12
12,240	0.13
12,270	0.12

*continued*

**Table 11. Total organic carbon analysis--continued**

<b>Depth</b>	<b>TOC %</b>
12,300	0.12
12,330	0.13
12,360	0.12
12,390	0.17
12,420	0.14
12,450	0.16
12,480	0.16
12,510	0.12
12,540	0.10
12,570	0.09
12,600	0.10
12,630	0.12
12,660	0.11
12,690	0.08
12,720	0.09
12,750	0.09
12,780	0.08
12,810	0.10
12,840	0.10
12,870	0.11
12,900	0.12
12,930	0.10
12,960	0.08
12,990	0.08
13,020	0.08
13,050	0.07
13,080	0.09
13,110	0.12
13,140	0.10
13,170	0.09
13,200	0.09
13,230	0.09
13,260	0.09
13,290	0.08
13,320	0.10
13,350	0.10
13,380	0.13
13,410	0.20

*continued*

*continued*

<b>Depth</b>	<b>TOC %</b>
13,440	0.18
13,470	0.20
13,500	0.17
13,530	0.13
13,560	0.14
13,590	0.13
13,620	0.06
13,650	0.09
13,680	0.11
13,710	0.09
13,740	0.10
13,770	0.10
13,800	0.09
13,830	0.09
13,860	0.10
13,890	0.14
13,920	0.15
13,950	0.14
13,980	0.13
14,010	0.10
14,040	0.10
14,070	0.15
14,100	0.15
14,130	0.12
14,160	0.11
14,190	0.11
14,220	0.12
14,250	0.08
14,280	0.07
14,310	0.07
14,340	0.10
14,370	0.12
14,400	0.10
14,460	0.08
14,490	0.10
14,430	0.11
14,520	0.09

*continued*

*continued*

<b>Depth</b>	<b>TOC %</b>
14,550	0.09
14,580	0.14
14,610	0.09
14,640	0.09
14,670	0.10
14,700	0.09
14,730	0.11
14,760	0.11
14,790	0.10
14,820	0.11
14,850	0.09
14,880	0.07
14,910	0.06
14,940	0.08
14,970	0.08
15,000	0.08
15,030	0.08
15,060	0.08
15,080	0.07
15,090	0.08
15,120	0.06
15,150	0.08
15,180	0.09
15,210	0.06
15,240	0.06
15,270	0.07
15,300	0.10
15,330	0.09
15,360	0.06
15,390	0.08
15,420	0.06
15,450	0.07
15,480	0.09
15,510	0.07
15,540	0.08
15,570	0.12

The Upper Jurassic kerogens are more terrestrial (more herbaceous, woody, and coaly) than those of the overlying section. However, borderline maturity may not be adequate to generate hydrocarbons from a terrestrial source, and these rocks are also too organically lean for hydrocarbon generation.

A TAI value of 2.9 is indicated at 13,380 feet, in Middle Jurassic rocks. Although this thermal level is fully adequate for hydrocarbon production, the terrigenous

kerogens of the Middle Jurassic rocks penetrated by this well are organically very lean, containing a maximum of 0.2 percent TOC.

Any significant volumes of oil or gas would have to have been generated in richer rocks elsewhere, likely deeper, and then have migrated into reservoir rocks penetrated by the well. However, no significant shows were encountered, and the Mobil LC Block 273 No. 1 well was plugged and abandoned.

## BURIAL HISTORY

The burial history model for the stratigraphic section penetrated by the Mobil LC Block 273 No. 1 well (figure 11) is based on biostratigraphic determinations contained in a report submitted by Mobil to MMS (figure 7) and the Cretaceous and Jurassic time scales of Van Hinte (1976a and 1976b). In general, burial diagrams for all Georges Bank wells show rapid Middle Jurassic subsidence followed by moderate and low burial rates through the rest of the Mesozoic and Cenozoic Eras. However, the Mobil LC Block 273 No. 1 profile differs from those

of the others in showing extremely rapid Jurassic burial and uniformly moderate subsequent burial. The former effect is due to an anomalously thick Kimmeridgian and Oxfordian section, according to Mobil's biostratigraphy. The latter effect is due to the lack of Upper Cretaceous and younger data. In constructing figure 11, no adjustments have been made for sedimentary compaction or for section removed by erosion.



## COMPANY-SUBMITTED DATA

Data and reports were submitted by Mobil Exploration and Producing Services, Inc., to MMS when the Mobil LC Block 273 No. 1 well was drilled, as required by Federal regulations and lease stipulations. Items of general geological, geophysical, and engineering usefulness are listed below. Items not listed include routine submittals required by regulation and detailed operations information, such as the Exploration Plan, Application for Permit to Drill, daily drilling reports, monthly reports, well location survey, and drilling pressure and temperature data logs. Well "electric" logs are listed in the **Formation Evaluation** chapter. Listed and unlisted company reports and data are available through the Public Information

Unit, Minerals Management Service, Gulf of Mexico OCS Region, 1201 Elmwood Park Boulevard, New Orleans, Louisiana 70123-2394; telephone (504)736-2519 or 1-800-200-GULF, FAX (504)736-2620. Well logs are available on microfilm from the National Geophysical Data Center, 325 Broadway Street, Boulder CO 80303-3337, attn. Ms Robin Warnken; telephone (303)497-6338, FAX (303)497-6513; e-mail rwarnken@NGDC.NOAA.GOV.

At a later date, additional original technical data, including well logs, will be added to the compact disk (CD) version of the Georges Bank well reports. The CD will be available from the Gulf of Mexico OCS Region Public Information Unit.

## SELECTED COMPANY-SUBMITTED DATA

Final Well Report (summaries of data and interpretations for: Drilling and engineering, formation pressures, geology, evaluation and testing, and data inventory), Exploration Logging of U.S.A., Inc.(Exlog), undated.

Velocity survey computation (well velocity and well seismic tool data), Schlumberger Ltd., Wireline Testing, Houston TX, undated.

Physical formation "mud" log, EXLOG, undated.

Wellsite descriptions of sidewall cores, Mobil, 09/06/82.  
No petrophysical analysis was done.

Biostratigraphic and organic geochemical studies (biostratigraphy, paleontology, paleoenvironments, thermal maturation, and organic geochemistry), Mobil Exploration and Producing Services Inc., Applied Stratigraphy, Dallas TX, 10/82.

At a later date, additional original technical data, including well logs, will be added to the compact disk (CD) version of the Georges Bank well reports. The CD will be available from the Gulf of Mexico OCS Region Public Information Unit.

## SELECTED REFERENCES

This list is compiled from published and unpublished Minerals Management Service and USGS Conservation Division reports on Georges Bank wells. Not all of the references could be located and verified.

- Albrecht, P., 1970, Etude de constituents organiques des series sedimentaries de Logbaba et Messel. Transformations deagenetiques: Universite de Strasbourg, Memoires du Service de la Charge Geologique d'Alsac et de Lorraine, no. 32, 119 p.
- Amato, R.V. and J.W. Bebout, 1978, Geological and Operational Summary, COST No. GE-1 Well, Southeast Georgia Embayment Area, South Atlantic OCS: U. S. Geological Survey Open-File Report 78-668, 122 p.
- Amato, R. V. and J. W. Bebout (eds.), 1980, Geologic and Operational Summary, COST No. G-1 Well, Georges Bank Area, North Atlantic OCS: U. S. Geological Survey Open-File Report 80-268, 112 p.
- Amato, R.V., and E.K. Simonis (eds.), 1979, Geologic and Operational Summary, COST No. B-3 Well, Baltimore Canyon Trough Area, Mid-Atlantic OCS: U.S. Geological Survey Open-File Report 79-1159, 118 p.
- Amato, R.V. and E.K. Simonis,(eds.), 1980, Geologic and Operational Summary, COST No. G-2 Well, Georges Bank Area, North Atlantic OCS: U. S. Geological Survey Open-File Report 80-269, 116 p.
- BBN-Geomarine Services Co., 1975, COST wellsite G-1, Georges Bank, engineering geology interpretation of high-resolution geophysical data: Houston, Texas, 11 p.
- Ballard, R. D. and E. Uchupi, 1975, Triassic rift structure in Gulf of Maine: American Association of Petroleum Geologists Bulletin, v. 59, no. 7, p. 1041-1072.
- Bayliss, G. S., 1980, Source-rock evaluation reference manual: Houston, Texas, Geochem Laboratories, Inc., 80 p.
- Bebout, J. W., 1980, Observed stratigraphic distribution of spores, pollen, and *incertae sedis* palynomorphs in the Tertiary section of the COST No. B-2 well, Baltimore Canyon, Atlantic Outer Continental Shelf: Palynology, v. 4, p. 181-196.
- Bebout, J. W., 1981, An informal palynologic zonation for the Cretaceous System of the United States Mid-Atlantic (Baltimore Canyon area) Outer Continental Shelf: Palynology, v. 5, p. 159-194.
- Berggren, W.A., D.V. Kent, C.C. Swisher III, and M.P. Aubry, 1995, A revised Cenozoic geochronology and chronostratigraphy; in Geochronology Time Scales and Global Stratigraphic Correlation, SEPM Special Publication no. 54, p. 129-212.
- Bhat, H., N. J. McMillan, J. Aubert, B. Porthault, and M. Surin, 1975, North American and African drift--the record in Mesozoic coastal plain rocks, Nova Scotia and Morocco, in Yorath, C. J., E. R. Parker, and D. J. Glass, (eds.), Canada's Continental Margins and Offshore Petroleum Exploration: Canadian Society of Petroleum Geologists Memoir 4, p. 375-389.
- Brideau, W. W. and W. C. Elsick, (eds.), 1979, Contributions of stratigraphic palynology (v. 2), Mesozoic Palynology: American Association of Stratigraphic Palynologists Contributions Series No. 4.

- Bronnimann, P., 1955, Microfossils *incertae sedis* from the Upper Jurassic and Lower Cretaceous of Cuba: *Micropaleontology*, v. 1, pp. 28, 2 pls., 10 text.
- Bujak, J. P., M. S. Barss, and G. L. Williams, 1977, Offshore east Canada's organic type and color and hydrocarbon potential: *Oil and Gas Journal*, v. 75, no. 15, p. 96-100.
- Bujak, J. P. and M. J. Fisher, 1976, Dinoflagellate cysts from the Upper Triassic of Arctic Canada: *Micropaleontology*, v. 22, p. 44-70, 9 pls.
- Bujak, J. P. and G. L. Williams, 1977, Jurassic palynostratigraphy of offshore eastern Canada, *in* Swain, F. M., (ed.), *Stratigraphic Micropaleontology of Atlantic Basin and Borderlands*: New York, Elsevier Scientific Publishing Co., p. 321-339.
- Bukry, D., 1969, Upper Cretaceous coccoliths from Texas and Europe: *University of Kansas Paleontological Contributions*, Art. 5 (Protista 2), p. 1-9, 50 pls., 1 text.
- Burk, C. A. and C. L. Drake, (eds.), 1974, *Geology of Continental Margins*: New York, Springer-Verlag, 1,009 p.
- Burke, K., 1975, Atlantic evaporites formed by evaporation of water spilled from Pacific, Tethyan, and southern oceans: *Geology*, v. 3, no. 11, p. 613-616.
- Cepek, P. and W. W. Hay, 1970, Zonation of the Upper Cretaceous using calcareous nannoplankton: *Palaontologische Abhandlungen, Abteilung B Palabotanik, Band III, Heft 3/4*, p. 333-340.
- Cita, M. B. and S. Gartner, 1971, Deep Sea Upper Cretaceous from the western North Atlantic: *in* *Proceedings II International Planktonic Conference, Roma, 1970*: Rome, Edizioni Tecnoscienza, v. 1, p. 287-319.
- Clarke, R. F. A. and J. P. Verdier, 1967, An investigation of microplankton assemblages from the chalk of the Isle of Wight, England: *Verhandelingen der Koninklijke Nederlandse Akademie van Wetenschappen, Afdeling Natuurkunde, and Eerste Reeks*, 24, p. 1-96.
- Claypool, G. E., C. M. Lubeck, J. P. Baysinger, and T. G. Ging, 1977, Organic geochemistry, *in* Scholle, P. A., (ed.), *Geological studies on the COST No. B-2 well, U. S. Mid-Atlantic Outer Continental Shelf area*: U. S. Geological Survey Circular 750, p. 46-59.
- Connan, J. 1974, Time-temperature relation in oil genesis: *American Association of Petroleum Geologists Bulletin*, v. 58, no. 12, p. 2516-2521.
- Core Laboratories, Inc., 1976, *Core studies, COST Atlantic well No. G-1, Georges Bank, Offshore Atlantic Ocean*: Dallas, Texas, 153 p.
- Core Laboratories, Inc., 1977a, *Core studies, COST Atlantic well No. G-2, Georges Bank, Offshore Atlantic Ocean*: Dallas, Texas, 298 p.
- Core Laboratories, Inc., 1977b, *Geochemical service report, COST G-2 Atlantic well, Georges Bank, offshore Massachusetts, U. S. A.*: Dallas, Texas, 147 p.
- Council on Environmental Quality, 1974, *OCS oil and gas--An environmental assessment--A report to the President by the Council on Environmental Quality*: Washington, D. C. (U. S. Government Printing Office), Stock No. 4000-00322, v. 1, 214 p.

- Cousminer, H. L., 1984, Canadian dinoflagellate zones (Middle Jurassic to Middle Eocene) in Georges Bank Basin (abstract): Proceedings of the American Association of Stratigraphic Palynologists, Arlington, Virginia, v. 9, p. 238.
- Cousminer, H. L., W. E. Steinkraus, and C. E. Fry, 1982, Biostratigraphy and thermal maturation profile, Exxon 133 No. 1 (OCS-A-0170) well section: Unpublished Report, Minerals Management Service.
- Cousminer, H. L., W. E. Steinkraus, and R. E. Hall, 1984, Biostratigraphic restudy documents Triassic/Jurassic section in Georges Bank COST G-2 well (abstract): Proceedings of the American Association of Petroleum Geologists, Annual Meeting, San Antonio, Texas, v. 68, no. 4, p. 466.
- Davey, R. J., 1979, The stratigraphic distribution of dinocysts in the Portlandian (latest Jurassic) to Barremian (Early Cretaceous) of northwest Europe: American Association of Stratigraphic Palynologists Contributions, Series No. 5B, p. 49-81.
- Davey, R. J. and J. P. Verdier, 1974, Dinoflagellate cysts from the Aptian type sections at Gargas and La Bedoule, France: Paleontology, v. 17, pt. 3, p. 623-653.
- Davies, E. H., 1985, The miospore and dinoflagellate cyst zonation of the Lias of Portugal: Palynology, v. 9, p. 105-132.
- Dorhofer, G. and E. H. Davies, 1980, Evolution of archeopyle and tabulation in Rhaetogonyaulacian dinoflagellate cysts: Royal Ontario Museum, Life Sciences Miscellaneous Publications, p. 1-91, fig. 1-40.
- Dow, W. G., 1974, Application of oil-correlation and source-rock data to exploration in Williston Basin: American Association of Petroleum Geologists Bulletin, v. 58, no. 7, p. 1253-1262.
- Dow, W. G., 1977, Kerogen studies and geological interpretations: Journal of Geochemical Exploration, v. 7, p. 79-99.
- Drake, C. L., J. I. Ewing, and H. Stockard, 1968, The continental margin of the eastern United States: Canadian Journal of Earth Science, v. 5, no. 4, p. 993-1010.
- Drake, C. L., M. Ewing, and G. H. Sutton, 1959, Continental margins and geosynclines--The east coast of North America north of Cape Hatteras, *in* Aherns, L. H., and others, (eds.), Physics and Chemistry of the Earth, v. 3: New York, Pergamon, p. 110-198.
- Eliuk, L. S., 1978, the Abenaki Formation, Nova Scotia, Canada--A depositional and diagenetic model for a Mesozoic carbonate platform: Bulletin of Canadian Petroleum Geology, v. 26, no. 4, p. 424-514.
- Emery, K. O. and E. Uchipi, 1972, Western North Atlantic Ocean--Topography, rocks, structure, water, life, and sediments: American Association of Petroleum Geologists Memoir 17, 532 p.
- Evitt, W. R., (ed.), 1975, Proceedings of a forum on dinoflagellates: American Association of Stratigraphic Palynologists Contributions, Series No. 4, 76 p.
- Folger, D. W., 1978, Geologic hazards on Georges Bank--an overview: Geological Society of America Abstracts with Programs, v. 10, no. 1, p. 42.
- Fry, C. E., 1979, Geothermal gradient, *in* Amato, R. V. and E. K. Simonis (eds.), Geologic and Operational Summary, COST No. B-3 well, Baltimore Canyon Trough Area, Mid-Atlantic OCS: U. S. Geological Survey Open-File Report 79-1159, p. 64-65.

- Gartner, S., Jr., 1968, Coccoliths and related calcareous nannofossils from Upper Cretaceous deposits of Texas and Arkansas: University of Kansas Paleontological Contributions, no. 48, Protista, v. 48, Art. 1, p. 1-56.
- GeoChem Laboratories, Inc., 1976, Hydrocarbon source facies analysis, COST Atlantic G-1 well, Georges Bank, offshore Eastern United States: Houston, Texas, 10 p.
- GeoChem Laboratories, Inc., 1977, Hydrocarbon source facies analysis, COST Atlantic G-2 well, Georges Bank, offshore eastern United States: Houston, Texas, 66 p.
- Gibson, T. G., 1970, Late Mesozoic-Cenozoic tectonic aspects of the Atlantic coastal margin: Geological Society of America Bulletin, v. 81, no. 6, p. 1813-1822.
- Gitmez, G. U. and W. A. S. Sarjeant, 1972, Dinoflagellate cysts and acritarchs from the Kimmeridgian (Upper Jurassic) of England, Scotland and France: Bulletin of the British Museum of Natural History: Geology, v. 21, p. 171-257.
- Given, M. M., 1977, Mesozoic and Early Cenozoic geology of offshore Nova Scotia: Bulletin of Canadian Petroleum Geology, v. 25, p. 63-91.
- Gocht, H., 1970, Dinoflagellaten-Zysten aus dem Bathonium des erdolfeldes Aldorf (Northwest-Setuschland): Palaeontographica, Abt. B., v. 129, p. 125-165.
- Gorka, H., 1963, Coccolithophorides, Dinoflagellates, Hystrichosphaerides et microfossiles *incertae sedis* du Cretace superier de Pologne: Acta Palaeontologica Polonica, v. 8, p. 1-82.
- Gradstein, F.M., F.P.Achterberg, J.G. Ogg, J.Hardenbol, P. van Veen, and Z. Huang, 1995, A Triassic, Jurassic, and Cretaceous time scale; *in* Geochronology Time Scales and Stratigraphic Correlation, SEPM Special Publication no. 54, p. 95-126.
- Grose, P. L. and J. S. Mattson, 1977, The Argo Merchant oil spill--A preliminary scientific report: National Oceanic and Atmospheric Administration Environmental Research Laboratories, 129 p.
- Grow, J. A., R. E. Mattick, and J. S. Schlee, 1979, Multichannel seismic depth sections and interval velocities over continental shelf and upper continental slope between Cape Hatteras and Cape Cod, *in* Watkins, J. S., L. Montadert, and P. W. Dickerson, (eds.), Geological and Geophysical Investigations of Continental Margins: American Association of Petroleum Geologists Memoir 29, p. 65-83.
- Harwood, R. J., 1977, Oil and gas generation by laboratory pyrolysis of kerogen: American Association of Petroleum Geologists Bulletin, v. 61, no. 12, p. 2082-2102.
- Hill, M. E., III, 1976, Lower Cretaceous Nannofossils from Texas and Oklahoma: Paleontographica, Abteilung B, 156, Lfg. 4-6, p. 103-179.
- Hunt, J. M., 1967, The origin of petroleum in carbonate rocks: *in* G. V. Chilingar, H. S. Bissell, and R. W. Fairbridge, (eds.), Carbonate Rocks: New York, Elsevier, p. 225-251.
- Hunt, J. M., 1974, Hydrocarbon and kerogen studies, *in* C. C von der Borch and others, Initial Reports of the Deep Sea Drilling Project, v. 22: Washington, D. C., U. S. Government Printing Office, p. 673-675.
- Hunt, J. M., 1978, Characterization of bitumens and coals: American Association of Petroleum Geologists Bulletin, v. 62, no. 2, p. 301-303.
- Hunt, J. M., 1979, Petroleum Geochemistry and Geology: San Francisco, W. H. Freeman Co., p. 273-350.

- Hurtubise, D. O. and J. H. Puffer, 1985, Nepheline normative alkalic dolerite of the Georges Bank Basin, North Atlantic, part of an Early Cretaceous eastern North American alkalic province: Geological Society of America, Northeastern Section, 20th Annual Meeting, 1985, v. 17, no. 1, p. 25.
- Hurtubise, D. O., J. H. Puffer, and H. L. Cousminer, 1987, An offshore Mesozoic igneous sequence, Georges Bank Basin, North Atlantic: Geological Society of America Bulletin, v. 98, no. 4, p. 430-438.
- International Biostratigraphers, Inc., 1976, Biostratigraphy of the COST G-1 Georges Bank test: Houston, Texas, 16 p.
- International Biostratigraphers, Inc., 1977, Biostratigraphy of the COST G-2 Georges Bank test: Houston, Texas, 16 p.
- Jansa, L. F. and J. A. Wade, 1975, Geology of the continental margin off Nova Scotia and Newfoundland, *in* W. J. M van der Linden and J. A. Wade (eds.), Offshore Geology of Eastern Canada: Geological Survey of Canada Paper 74-30, v. 2, p. 51-105.
- Jansa, L. F. and J. Wiedmann, 1982, Mesozoic-Cenozoic development of the eastern North American and northwest African continental margins: a comparison, *in* V. von Rad, K. Hinz, M. Sarnthein, and E. Seibold (eds.), Geology of the Northwest African Continental Margin: Berlin, Springer-Verlag, p. 215-269.
- Jansa, L. F., G. L. Williams, J. A. Wade, and J. P. Bujak, 1978, COST B-2 well (Baltimore Canyon) and its relation to Scotian Basin (abstract): American Association of Petroleum Geologists Bulletin, v. 62, no. 3, p. 526.
- Jones, R. W. and T. A. Edison, 1978, Microscopic observations of kerogen related to geochemical parameters with emphasis on thermal maturation, *in* D. F. Oltz (ed.), Geochemistry: Low Temperature Metamorphism of Kerogen and Clay Minerals: Society of Economic Paleontologists and Mineralogists, Pacific Section, Annual Meeting, Los Angeles, p. 1-12.
- Kent, D. V. and F. M. Gradstein, 1986, A Jurassic to Recent chronology, *in* P. R. Vogt and B. E. Tucholke (eds.), The Geology of North America, vol. M, The Western North Atlantic Region: Geological Society of America, p. 45-50.
- King, L. H. and B. MacLean, 1975, Geology of the Scotian Shelf and adjacent areas: Canadian Geological Survey Paper 74-23, p. 22-53.
- Kinsman, D. J. J., 1975, Rift Valley basins and sedimentary history of trailing continental margins, *in* A. G. Fisher and S. Judson, (eds.), Petroleum and Global Tectonics: Princeton, Princeton University Press, p. 83-126.
- Kjellstrom, G., 1973, Maastrichtian microplankton from the Hollviken borehole No. 1 in Scania, southern Sweden: Sveriges Geologiska Undersokning, Afhandlingar och Uppsatser, v. 7, p. 1-59.
- Landes, K. K. 1967, Eometamorphism and oil and gas in time and space: American Association of Petroleum Geologists Bulletin, v. 51, no. 6, p. 828-841.
- LaPlante, R. E., 1974, Hydrocarbon generation in Gulf Coast tertiary sediments: American Association of Petroleum Geologists Bulletin, v. 58, no. 7, p. 1281-1289.

- Larskaga, Ye. S. and D. V. Zhabreu, 1964, Effects of stratal temperatures and pressures on the composition of dispersed organic matter (from the example of the Mesozoic-Cenozoic deposits of the Western Ciccaspian region): Dokl. Akad. Nauk SSSR, v. 157, no. 4, pp. 135-139.
- Lentin, J. K. and G. L. Williams, 1981, Fossil Dinoflagellates, Index to Genera and Species: Bedford Institute of Oceanography Report Series B1-R-81-12, p. 1-345.
- Louis, M. C. and B. P. Tissot, 1967, Influence de la temperature et de la pression sur la formation des hydrocarbures dans les argiles a kerogen [Influence of temperature and pressure on the generation of hydrocarbons in shales containing kerogen], *in* 7th World Petroleum Congress, Proceedings, (Mexico), v. 2: Chichester, International, John Wiley and Sons, p. 47-60.
- Lowell, J. D., G. J. Genik, T. H. Nelson, and P. M. Tucker, 1975, Petroleum and plate tectonics of the southern Red Sea, *in* A. G. Fisher and S. Judson, (eds.), Petroleum and Global Tectonics: Princeton University Press, Princeton, p. 129-153.
- McIver, N. L., 1972, Cenozoic and Mesozoic stratigraphy of the Nova Scotia shelf: Canadian Journal of Earth Sciences, v. 9, p. 54-70.
- MacLean, B.C., and J.A. Wade, 1992, Petroleum geology of the continental margin south of the islands of St. Pierre and Miquelon, offshore eastern Canada; Bulletin of Canadian Petroleum Geology, v. 40, no. 3, p. 222-253.
- Maher, J. C., 1971, Geologic Framework and Petroleum Potential of the Atlantic Coastal Plain and Continental Shelf: U. S. Geological Survey Professional Paper 659, 98 p.
- Martini, E., 1971, Standard Tertiary and Quaternary calcareous nannoplankton zonation *in* Proceedings II International Planktonic Conference, Roma, 1970: Rome, Edizioni Tecnoscienza, p. 739-785.
- Mattick, R. E., R. Q. Foote, N. L. Weaver, and M. S. Grim, 1974, Structural framework of United States Atlantic Outer Continental Shelf north of Cape Hatteras: American Association of Petroleum Geologists Bulletin, v. 58, no. 6, 1179-1190.
- Miller, R. E., H. E. Lerch, G. E. Claypool, M. A. Smith, D. K. Owings, D. T. Lignon, and S. B. Eisner, 1982, Organic geochemistry of the Georges Bank basin COST Nos. G-1 and G-2 wells, *in* P. A. Scholle and C. R. Wenkam (eds.), Geological Studies of the COST Nos. G-1 and G-2 Wells, Unites States North Atlantic Outer Continental Shelf: U. S. Geological Survey Circular 861, p. 105-142.
- Miller, R. E., R. E. Mattick, and H. E. Lerch, 1981, Petroleum geochemistry and geology of Cenozoic and Mesozoic sedimentary rocks from Georges Bank basin (abstract): American Association of Petroleum Geologists Bulletin, v. 65, no. 9, p. 1667.
- Miller, R. E., D. M. Schultz, G. E. Claypool, H. E. Lerch, D. T. Lignon, C. Gary, and D. K. Owings, 1979, Organic geochemistry, *in* , P. A. Scholle (ed.), Geological Studies of the COST GE-1 Well, United States South Atlantic Outer Continental Shelf Area: U. S. Geological Survey Circular 800, p. 74-92.
- Miller, R. E., D. M. Schultz, G. E. Claypool, M. A. Smith, H. E. Lerch, D. Ligon, D. K. Owings, and C. Gary, 1980, Organic geochemistry, *in* P.A. Scholle (ed.), Geological Studies of the COST No. B-3 Well, United States Mid-Atlantic Continental Slope Area: U. S. Geological Survey Circular 833, p. 85-104.
- Miller, R. E., D. M. Schultz, H. E. Lerch, D. T. Lignon, and P. C. Bowker, 1986, *in* Edson, G. M.(ed.), Shell Wilmington Canyon 586-1 Well, Geological and Operation Summary: Minerals Management Service, OCS Report MMS 86-0099, p. 37-44.

- Miller, R. E., D. M. Schultz, H. E. Lerch, D. T. Lignon, and P. C. Bowker, 1987, *in* Edson, G. M. (ed.), Shell Wilmington Canyon 587-1 Well, Geological and Operation Summary: Minerals Management Service, OCS Report MMS 87-0074, p. 39-46.
- Momper, J. A., 1978, Oil migration limitations suggested by geological and geochemical considerations, *in* Physical and Chemical Constraints on Petroleum Migration: American Association of Petroleum Geologists, Continuing Education Course Note Series No., 8, p. B1-B60.
- Morbey, S. J., 1975, The palynostratigraphy of the Rhaetian Stage Upper Triassic in the Kerdelbachgraben Austria: *Paleontographica Abt. B*, v. 152, p. 1-75, p. 1-19.
- Murray, G. E., 1961, *Geology of the Atlantic and Gulf Coastal Provinces of North America*: New York, Harper, 692 p.
- Orr, W. L., 1974, Changes in sulfur content and isotopic ratios of sulfur during petroleum maturation--study of Big Horn Basin Paleozoic oils: *American Association Petroleum Geologists Bulletin*, v. 58, no. 11, p. 2295-2318.
- Perry, W. J., J. P. Minard, E. G. A. Weed, E. I. Robbins, and E. C. Rhodehamel, 1975, Stratigraphy of the Atlantic continental margin of the United States north of Cape Hatteras--brief survey: *American Association of Petroleum Geologists Bulletin*, v. 59, no. 9, p. 1529-1548.
- Phillipi, G. T., 1957, Identification of oil-source beds by chemical means, *in* 20th International Geological Congress Proceedings: Mexico City (1956), Sec. 3, p. 25-38.
- Phillipi, G.T., 1965, On the depth, time, and mechanism of petroleum generation: *Geochim. Cosmochim. Acta*, v. 29, p. 1021.
- Postuma, J. A., 1971, *Manual of Planktonic Foraminifera*: New York, Elsevier, 420 p.
- Pusey, W. C., III, 1973, The ESR-kerogen method--how to evaluate potential gas and oil source rocks: *World Oil*, v. 176, no. 5, p. 71-75.
- Reinhardt, P., 1966, Zur taxonomie und biostratigraphie des fossilen nannoplanktons aus dem Malm, der Kreide und dem Alttertiar Mitteleuropas [Taxonomy and biostratigraphy of Malm, Cretaceous, and early Tertiary nannoplanktonic faunas of central Europe], *Frieberger Forschungshefte, Reihe C: Geowissenschaften, Mineralogie-Geochemie*, 196 Paleont.: Leipzig, Bergakademie Freiberg, p. 5-61.
- Ricciardi, K. (ed.), 1989, Exxon Lydonia Canyon 133-1 Well, Geological and Operational Summary: Minerals Management Service OCS Report MMS 89-0007, 46 p.
- Riding, J. B., 1984, Dinoflagellate cyst range-top biostratigraphy of the uppermost Triassic to lowermost Cretaceous of northwest Europe: *Palynology*, v.8, p. 195-210.
- Robbins, E. I. and E. C. Rhodehamel, 1976, Geothermal gradients help predict petroleum potential of Scotian Shelf: *Oil & Gas Journal*, v. 74, no. 9, p. 143-145.
- Rona, P. A., 1973, Relations between rates of sediment accumulation on continental shelf, sea-floor spreading, and eustasy inferred from central North Atlantic: *Geological Society of America Bulletin*, v. 84, no. 9, p. 2851-2872.
- Ryan, W. B. F., M. B. Cita, R. L. Miller, D. Hanselman, B. Hecker, and M. Nibbelink, 1978, Bedrock geology in New England submarine canyons: *Oceanologia Acta*, v. 1, no. 2, p. 233-254.

- Sarjeant, W. A. S., 1979, Middle and Upper Jurassic dinoflagellate cysts--the world excluding North America: American Association of Stratigraphic Palynologists Contributions Series no. 5-B, p. 133-157.
- Schlee, J. S., J. C. Behrendt, J. A. Grow, J. M. Robb, R. E. Mattick, P. T. Taylor, and B. J. Lawson, 1976, Regional geologic framework off northeastern United States: American Association of Petroleum Geologists Bulletin, v. 60, no. 6, p. 926-951.
- Schlee, J. S., W. P. Dillon, and J. A. Dillon, 1979, Structure of the continental slope off the eastern United States, *in* L. J. Doyle and O. H. Pilkey, (eds.), Geology of Continental Slopes: Society of Economic Paleontologists and Mineralogists Special Publication 27, p. 95-117.
- Schlee, J.S. and K.D. Klitgord, 1988, Georges Bank basin: a regional synthesis; *in* R.E. Sheridan and J.A. Grow (eds.), The Geology of North America, vol. I-2, The Atlantic Continental Margin, Geological Society of America, p. 243-268.
- Schlee, J. S., R. G. Martin, R. E. Mattick, W. P. Dillon, and M. M. Ball, 1977, Petroleum geology of the U. S. Atlantic--Gulf of Mexico margins, *in* V. S. Cameron (ed.), Exploration and Economics of the Petroleum Industry--New Ideas, Methods, New Developments: Southwestern Legal Foundation: New York, Mathew Bender and Co., v. 15, p. 47-93.
- Schlee, J. S., R. E. Mattick, D. J. Taylor, O. W. Girard, E. C., Rhodehamel, W. J. Perry, and K. C. Bayer, 1975, Sediments, structural framework, petroleum potential, environmental conditions and operation considerations of the United States North Atlantic Outer Continental Shelf: U. S. Geological Survey, Open-File Report 75-353, 179 p.
- Scholle, P. A. and C. R. Wenkam (eds.), 1982, Geological studies of the COST Nos. G-1 and G-2 wells, United States North Atlantic OCS: U. S. Geological Survey Circular 861, 193 p.
- Schultz, L. K. and R. L. Grover, 1974, Geology of Georges Bank Basin: American Association of Petroleum Geologists Bulletin, v. 58, no. 6, p. 1159-1168.
- Schwab, K.W., P. van Gijssel, and M.A. Smith, 1990, Kerogen evolution and microscopy workshop short course, International Symposium on Organic Petrology, Zeist, the Netherlands, January 10 and 11, 1990 (unpublished).
- Shell Canada Limited, 1970a, Well history report, Oneida O-25, 50 p.
- Shell Canada Limited, 1970b, Well history report, Mohawk B-93, 25 p.
- Shell Canada Limited, 1972, Well history report, Mohican I-100, 76 p.
- Sheridan, R. E., 1974a, Conceptual model for the block-fault origin of the North American Atlantic continental margin geosyncline: Geology, v. 2, no. 9, p. 465-468.
- Sheridan, R. E., 1974b, Atlantic continental margin of North America, *in* C. A. Burk and C. L. Drake, (eds.), Geology of Continental Margins: New York, Springer-Verlag, p. 391-407.
- Sheridan, R. E., 1976, Sedimentary basins of the Atlantic margin of North America: Tectonophysics, v. 36, p. 113-132.
- Sherwin, D. F., 1973, Scotian Shelf and Grand Banks, *in* R. G. McCrossan (ed.), Future Petroleum Provinces of Canada--Their Geology and Potential: Canadian Society of Petroleum Geologists Memoir 1, p. 519-559.

- Singh, C., 1971, Lower Cretaceous microfloras of the Peace River area, northwestern Alberta: Research Council of Alberta Bulletin 28, 2 volumes, 542 p.
- Smith, H. A., 1975, Geology of the West Sable structure: Bulletin of Canadian Petroleum Geology, v. 23, no. 1, p. 109-130.
- Smith, M. A., 1979, Geochemical analysis, *in* R. V. Amato and E. K. Simonis (eds.), Geologic and Operational Summary, COST No. B-3 Well, Baltimore Canyon Trough Area, Mid-Atlantic OCS: U. S. Geological Survey Open-File Report 79-1159, p. 81-99.
- Smith, M. A., 1980, Geochemical analysis, *in* R.V. Amato and E.K. Simonis (eds.), Geologic and Operational Summary, COST No. G-2 Well, Georges Bank Area, North Atlantic OCS: U. S. Geological Survey Open-File Report, 80-269, p. 77-99.
- Smith, M. A., 1995, Assessment of U.S. Atlantic hydrocarbon resources using new geochemical technology: U.S. Geological Society of America, Abstracts with programs, 1995 Annual Meeting, New Orleans, LA.
- Smith, M.A., R.V. Amato, M.A. Furbush, D.M. Pert, M.E. Nelson, J. S. Hendrix, L.C. Tamm, G. Wood, Jr., and D.R. Shaw, 1976, Geological and Operational Summary, COST No. B-2 Well, Baltimore Canyon Trough Area, Mid-Atlantic OCS: U. S. Geological Survey Open-File Report 76-774, 79 p.
- Smith, M. A. and D. R. Shaw, 1980, Geochemical analysis, *in* R. V. Amato and J. W. Bebout (eds.), Geologic and Operational Summary, COST No. G-1 well, Georges Bank Area, North Atlantic OCS: U. S. Geological Survey Open-File Report 80-268, p. 81-94.
- Smith, M.A., and P. van Gijzel, 1990, New perspectives on the depositional and thermal history of Georges Bank; *in* W.J.J. Fermont and J.W. Weegink (eds.), Proceedings, International Symposium on Organic Petrology, Zeist, the Netherlands.
- Smith, R. A., J. R. Stack, and R. K. Davis, 1976, An oil spill risk analysis for the Mid-Atlantic Outer Continental Shelf lease area: U. S. Geological Survey Open-File Report 76-451, 24 p.
- Staplin, F. L., 1969, Sedimentary organic matter, organic metamorphism, and oil and gas occurrence: Bulletin of Canadian Petroleum Geology, v. 17, no. 1, p. 47-66.
- Steinkraus, W. E., 1980, Biostratigraphy, *in* R. V. Amato and J. W. Bebout, (eds.), Geologic and Operation Summary, COST No. G-1 Well, Georges Bank, North Atlantic OCS: U. S. Geological Survey Open-File Report 80-268, p. 39-51.
- Stewart, H. B., Jr. and G. F. Jordan, 1964, Underwater sand ridges on Georges Shoal, *in* R. L. Miller (ed.), Papers in Marine Geology, Shepard Commemorative Volume: New York, Macmillan, p. 102-114.
- Tamm, L. C., 1978, Electric log interpretations, *in* R. V. Amato and J. W. Bebout (eds.), Geological and Operational Summary, COST No. GE-1 Well, Southeast Georgia Embayment Area, South Atlantic OCS: U. S. Geological Survey Open-File Report 78-668, 61-75.
- Thierstein, H. R., 1971, Tentative Lower Cretaceous calcareous nannoplankton zonation: *Eclogae Geologicae Helveticae*, v. 64, p. 459-487.
- Tissolt, B. P. and D. H. Welte, 1978, Petroleum Formation and Occurrence, A New Approach to Oil and Gas Exploration: Berlin, Springer-Verlag, p. 123-201.

- Tissot, B., B. Durand, J. Espitalie, and A. Combaz, 1974, Influence of nature and diagenesis of organic matter in formation of petroleum: American Association of Petroleum Geologists Bulletin, v. 58, no. 3, p. 499-506.
- Tschudy, R. H., 1973, *Complexiopollis* Pollen Lineage in Mississippi Embayment Rocks: U. S. Geological Survey Professional Paper 743-C, p. C1-C15.
- Uchupi E. and K. O. Emery, 1967, Structure of continental margin off Atlantic coast of United States: American Association of Petroleum Geologists Bulletin, v. 51, no. 2, p. 223-234.
- U. S. Department of Commerce, 1973, Environmental Conditions within Specified Geographical Regions-- Offshore East and West Coast of the United States and in the Gulf of Mexico: Washington, D. C., National Oceanographic Data Center, National Oceanographic and Atmospheric Administration, 735 p.
- Van Gijzel, P., 1990, Transmittance colour index (TCI) of amorphous organic matter: a new thermal maturity indicator for hydrocarbon source rocks, and its correlation with mean vitrinite reflectance and thermal alteration index (TAI); in W.J.J. Fermont and J.W. Weegink, eds., Proceedings, International Symposium on Organic Petrology, Zeist, the Netherlands.
- Van Hinte, J. E., 1976a, A Jurassic time scale: American Association of Petroleum Geologists Bulletin, v. 60, no. 4, p. 489-497.
- Van Hinte, J. E., 1976b, A Cretaceous time scale: American Association of Petroleum Geologists Bulletin, v. 60, no. 4, p. 498-516.
- Vassoyevich, N. B., Yu. I. Korchagina, N. V. Lopatin, and V. V. Chernyshev, 1969, Glavanaya faza nefteobrazovaniya [Principal phase of oil formation]: Moskovskogo Universiteta Vestnik, Ser. 4, Geologii, v. 24, no. 6, p. 3-27: English translation in International Geology Review, 1970, v. 12, no. 11, p. 1,276-1,296.
- Wade, J.A., 1977, Stratigraphy of Georges Bank Basin-- interpretation from seismic correlation to the western Scotian Shelf: Canadian Journal of Earth Science, v. 14, no. 10, p. 2274-2283.
- Wade, J.A., G.R.Campbell, R.M. Proctor, and G.C. Taylor, 1989, Petroleum Resources of the Scotian Shelf, Geological Survey of Canada Paper 88-19.
- Walper, J. L. and R. E. Miller, 1985, Tectonic evolution of Gulf Coast basins, in B. F. Perkins and G. B. Martin (eds.), Habitat of Oil and Gas, Program and Abstracts, Fourth Annual Research Conference, Gulf Coast Section: Austin, Society of Economic Paleontologists and Mineralogists Foundation, Earth Enterprises, p. 25-42.
- Waples, D. W., 1980, Time and temperature in petroleum formation--application of Lopatin's method to petroleum exploration: American Association of Petroleum Geologists Bulletin, v. 64, no. 6, p. 916-926.
- Weed, E. G. A., J. P. Minard, W. J. Perry, Jr., E. C. Rhodehamel, and E. I. Robbins, 1974, Generalized pre-Pleistocene geologic map of the northern United States Atlantic continental margin: U. S. Geological Survey Miscellaneous Geologic Investigations Map I-861, Scale 1:1,000,000.
- Williams, G. L., 1974, Dinoflagellate and spore stratigraphy of the Mesozoic-Cenozoic offshore Eastern Canada, in Offshore Geology of Eastern Canada: Geological Survey of Canada Paper 74-30, v. 2, p. 107-161.
- Williams, G. L., 1977, Dinocysts--their classification, Biostratigraphy, and paleoecology, in A. T. S. Ramsay (ed.), Oceanic Micropaleontology, v. 2, New York, Academic Press, p. 1,231-1,326.

Williams, G. L. and W. W. Brideaux, 1975, Palynologic analyses of Upper Mesozoic and Cenozoic rocks of the Grand Banks, Atlantic Margin: Geological Survey of Canada Bulletin, v. 236, p. 1-163.

Woollam, R. and J. B. Riding, 1983, Dinoflagellate cyst zonation of the English Jurassic: Institute of Geological Sciences Report, v. 83, No. 2, p. 1.

Worsley, T. R., 1971, Calcareous nannofossil zonation of Upper Jurassic and Lower Cretaceous sediments from the Western Atlantic, *in* Proceedings II, International Planktonic Conference, Roma, 1970: Rome, Edizioni Tecnoscienza, p. 1301-1321 .